

# A multi-talented machining system

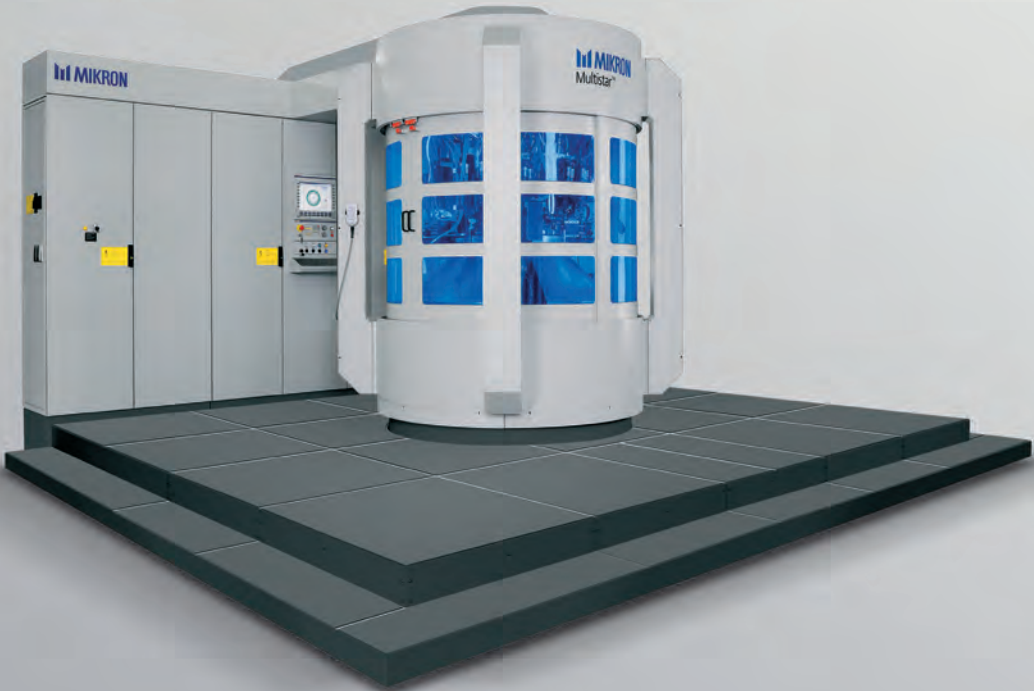

Mikron Multistar

# Mikron Multistar

A multi-talented machining system for small precision parts

Would you like to get into high volume manufacturing, or is this your specialty? Either way, you can give your manufacturing productivity a boost with Multistar. You can rely on Mikron Machining and take advantage of our solid mass production expertise of small precision parts!

## Where small parts come out big

Productivity, accuracy and quality have the highest priority at Mikron. When you buy a Multistar you acquire production machinery, which completely fulfills these requirements and proves itself as a worthwhile investment from day one on. Multistar – the ideal solution for profitable complete machining of small precision parts in large production volumes.

## Available Multistar Types

- LX: 24 stations
- CX: 24 stations, monoblock or adjustable stations
- NX: 24 stations, full CNC controlled

## At home almost anywhere

The Multistar transfer machine is well known for its wide range of applications. Parts for injection systems and gas burners, connectors for the electronics and electrical industry as well as components in the area of surgery, communication and audio-video are ideal Multistar workpieces. Multistar machines parts made from materials such as steel, non-ferrous metals or aluminum, in the diameter range from 0.4 to 30 mm with maximum lengths up to 60 mm.

## Convincing success factors

- Complete machining in one setting
- Highly accurate manufacturing and repeatability
- Very short cycle times
- System solution for economical high volume series production
- Production expertise and machining technology from a single source

## The advantages of Multistar at a glance

### Precision

- Compact precise design
- Stiff and thermally symmetric indexing plate
- Indexing plate positioning accuracy  $\pm 2.5\mu\text{m}$

### Productivity

- Up to 2 machining units per station
- Up to 44 perfectly synchronized units in use
- Single or multiple cycle (maximum 600 parts/minute)

### Flexibility

- Modular construction
- Simple and fast tool changes
- Optional CNC controlled units

### Versatile machining

- Drilling, milling, thread cutting, turning, recessing, deep-hole drilling, burnishing, grinding, edging
- Chiseling, stamping, bending and assembly
- Measuring and testing on intermediate stations
- Complex machining on CNC controlled stations



Typical Multistar workpieces  
made from steel, aluminum, brass, beryllium-bronze & copper

## Precision

# Mikron Multistar

## Accuracy under control

Mikron used all its knowledge and many years of experience when designing the Multistar. High quality manufacturing of the basic machine, compact, thermally symmetric design and perfect conformity of station supports and indexing plate are special Multistar features. Tight fitting spindles and spring chuck sets fitted with bearings and optimized cutting tools layout complete the perfect Mikron-precision concept.

### Repeated precision in the $\mu\text{m}$ range

Multistar provides unrivalled accuracy even when it comes to positioning of the turntable after rotation. Two diametrically opposite indexing pins, which guarantee a rigid blocking, lock the turntable in place during the machining phase. The table indexing accuracy is  $\pm 2.5\mu\text{m}$ .

### Relax with Multistar

The perfect interaction between all elements guarantees excellent machining quality even at high speeds and after long running periods. Multistar, your reliable partner for carefree high volume series production!

### Multistar precision in a league of its own

- Rigid, compact and thermally symmetric design
- $\pm 2.5\mu\text{m}$  table indexing accuracy
- High-precision Mikron spindles and spring chuck sets
- Measurement operations and dimensional corrections integrated into the machining process
- Direct separation of defective parts

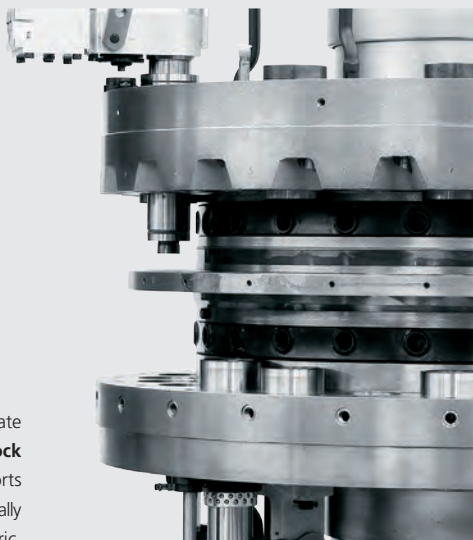
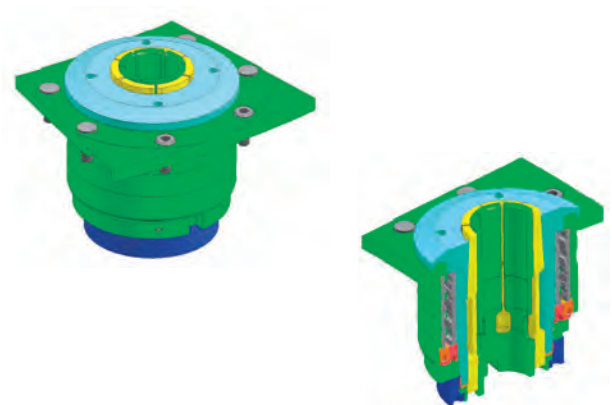

Indexing plate with **mono block** station supports compact and thermally symmetric.

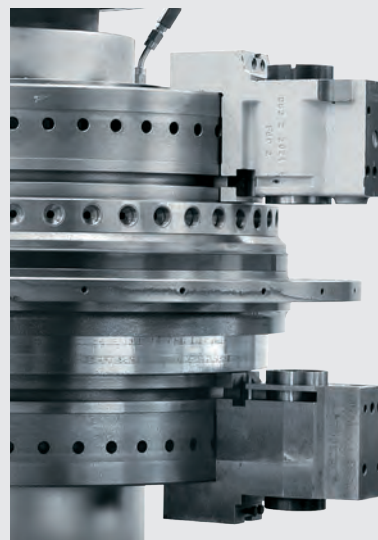

Indexing plate with adjustable supports compact and thermally symmetric.

### Spring chucks, a strategic element

Developed and manufactured by Mikron, the Multistar spring chucks fit perfectly to the machine concept.

#### Special features

- Safety: The chuck clamping force which is equally distributed on the parts outer edges, always ensures that the workpieces will not become deformed.
- Precision: Precise and compact spring chucks guarantee highly accurate repeatability.
- Productivity: Compact construction allows for a higher concentration of spring chuck in a tight space.
- Versatility: Ideal for round and randomly profiled parts with precise outer edges, up to a diameter of 30 mm.
- Orientation: The spring chucks can be turned to any position for transverse machining.
- Rotation: Rotating spring chucks with CNC drive ensure perfect concentricity for turning and plunge cutting operations.



Chuck spring set design



## Productivity

# Mikron Multistar

## The high volume professional

Multistar is outstanding due to its high productivity. Simultaneous double sided machining on 24 stations, at a cadence of 150 cycles per minute, guarantees an exceptional high output.

### **Fastest transfer machine in the world: Multistar from Mikron**

Multistar reaches turbo performance. How? The answer lies in the mechanical schematics: The drive motor propels a Geneva cross mechanism which, in turn, "clocks" the turntable. A frequency converter enables adjustment of the cycle times between 12 and 150 switching cycles per minute in order to match the particular requirements of each workpiece. The Mikron patented mechanical accelerator ensures maximum speed for the shortest cycle times.

### **prodigious + sensational = professional**

The centrally located drive allows for excellent access to the tools and to the work space. The tooling change can be made simply and quickly, machine stoppages are reduced to a minimum. No doubt about it ! Your plans work out with Multistar: It produces continuously and thus economically.

### **The productivity features at a glance**

- High number of stations, 24
- Up to 44 perfectly synchronous units in use
- Simultaneous double sided machining on one station
- High cutting power thanks to the machining spindles rotation speed of 32,000 rpm
- Short approach paths , optimized synchronization of the movement processes and quicker table feed, minimize dead time
- Allowed mechanical kinematics up to 150 cycles / minute
- Production performance for multiple cycles up to 600 parts per minute (4 x 150)
- Machining of different workpieces possible during dual cycle

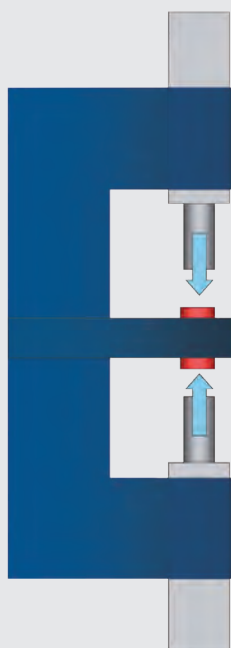

### **Simultaneous machining using two units**

Machining version above and below. Also side machining unit is possible.

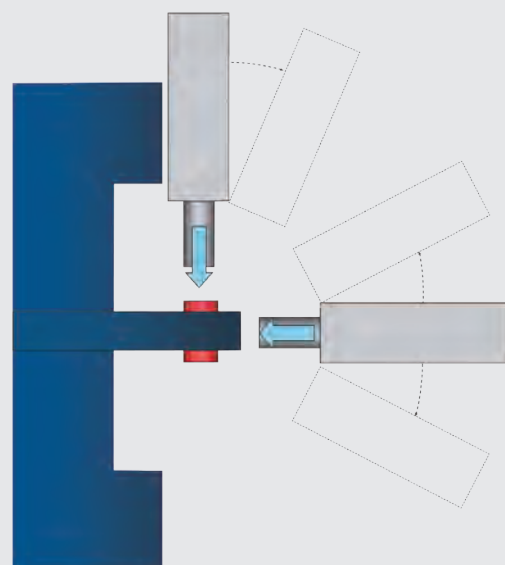

Adjustable station supports, shown in the vertical and horizontal position.

### **Multistar tooling change as fast as a formula 1 tire change**

The working spindles can be inserted into or released from the machining stations with very few steps. This allows practical tool setting to be carried out away from the machine with maximum accessibility. A second set of spindles optimizes use of the rapid tooling change. The operator can set the additional set, while the production with Multistar continues running. When reinstalling the spindles the precise positioning is equally quick and easy: Pre-loaded spherical liners ensure tight fitting guidance of the spindles. A fixed stop, which can be adjusted via a micrometer screw, limits the spindle feed. Multistar, your "racing car" which always runs at full speed and reduces "pit stops" to a minimum.



The Multistar can be fitted with different spindles



## Flexibility

# Mikron Multistar

To serve your needs

### Flexible in design

Multistar has a modular design and can be tailored to individual customer needs. The Mikron engineers set the highest possible standards. Special designs for stamping, bending and assembly tasks for insertion of bolts, balls and screws are daily challenges for our experts. Special measuring and testing units are also often developed for our customers and integrated into the manufacturing process.

### Flexible for re-tooling

CNC units expand the Multistar field of application. The plant with the CNC units is more flexible, re-tooling is greatly simplified. When are CNC units particularly useful? For demanding cutting tasks or for the production of "families" of parts. The Multistar™ NX-24 is a worthwhile investment even for lot sizes of a few thousand workpieces per version.

### Up to 4 CNC-axes on one station

CNC controlled working units are combined with rotating spring chucks for 4-axis interpolation. The workpiece can be positioned for machining or rotated for turning, at random.

### The control, your loyal friend and servant

The specially developed user friendly "Human Machine Interface" (HMI) from Mikron allows for simple and clear management of the installation. Management of the diagnostics and production data is greatly simplified. Faults are quickly localized once errors are indicated and the necessary corrective measures are carried out rapidly.

Productivity >



Multistar LX-24



Multistar CX-24



Multistar NX-24

Flexibility >



### Part specific handling

An optimized feed or unloading system belongs to a turnkey production installation. The feeding and unloading systems are as diverse as the blanks that have to be machined.

### Some examples of Multistar loading systems are:

- Vibratory, linear or inclined conveyor
- Pick-and-Place-System from feed belt or pallet
- Directly from the wire

### Some advantages, an overview

- Continuous production
- Large loading capacity ideal for continuous operation around the clock
- Guaranteed production control with ejection into selectors
- Integrated electronic quality control for selection of good/rejected parts



Feed with vibratory conveyor



Feed via pallets and robot arm



Feed directly from the wire

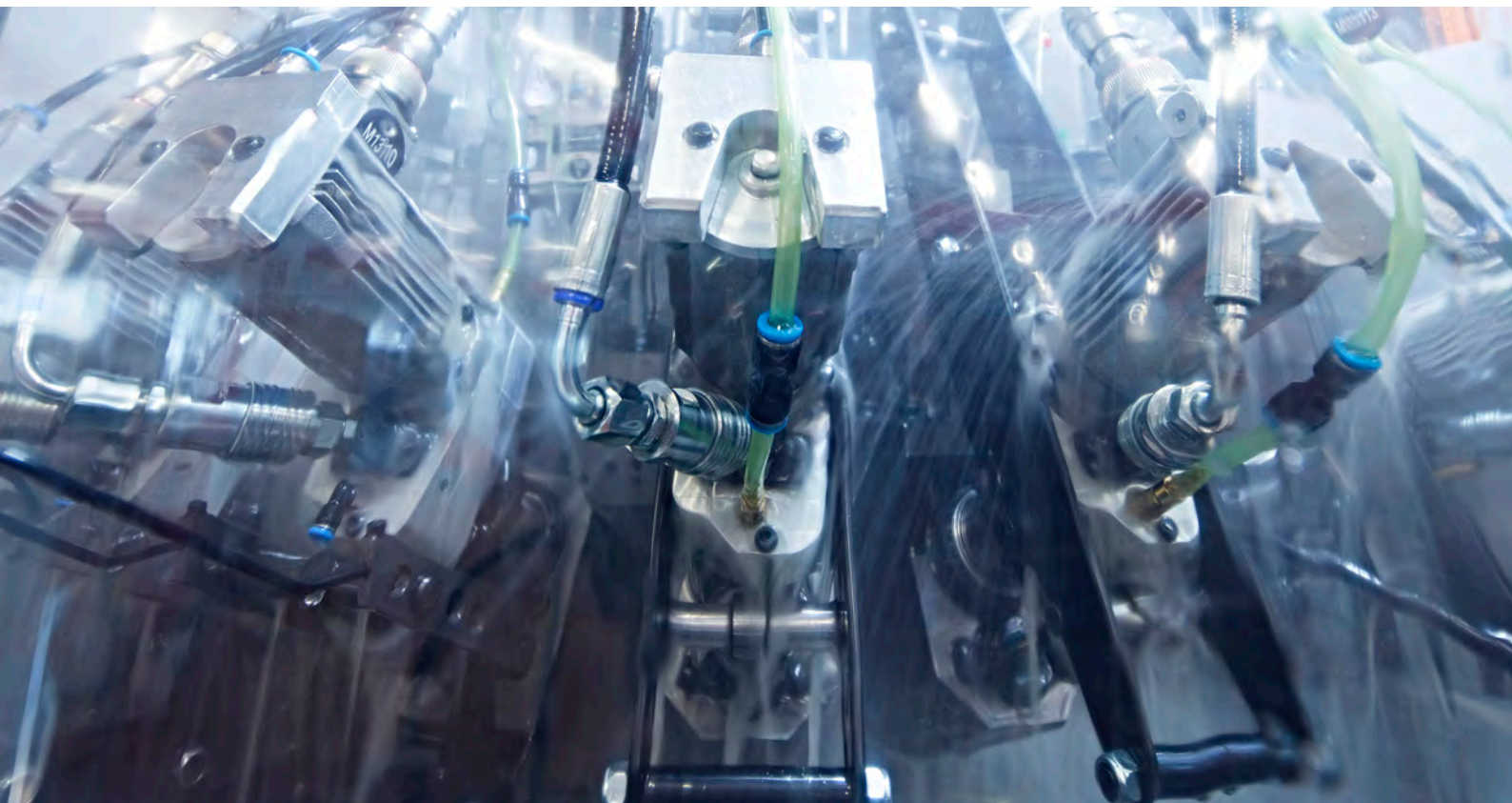

## Versatility

# Mikron Multistar

for quantity with quality!

Multistar permits a wide variety of machining operations. It is possible to carry out simple machining processes such as drilling or complex milling operations with 4-axis interpolation, depending on the machine model and configuration. And still another unique plus: You can completely finish your workpieces, starting from blanks and ending with ready to install components.

### That's what sets Multistar apart

- Efficient, part specific feed
- Complete machining of the workpiece
- Integrated, automatic separation of defective parts

### Multistar machining and handling to get your attention

- Outside diameter pre and final turning
- Axial and radial holes
- Inside and outside thread cutting, milling and chamfering
- Turning over or re-positioning of the workpiece
- Testing of shear and tensile forces when attaching and detaching plug and connector
- Manufacturing of complete connectors using dual cycle (plug and connector)

The combination of manufacturing, part assembly and quality checks provides you with peace of mind at the highest productivity and creates the best conditions for economical production. Do you want quality quantities? Multistar is the right solution.



Feed with vibratory conveyor



Loading



Pre turning on top, drilling from below



Milling (slots)



Part turn-over in different section collet

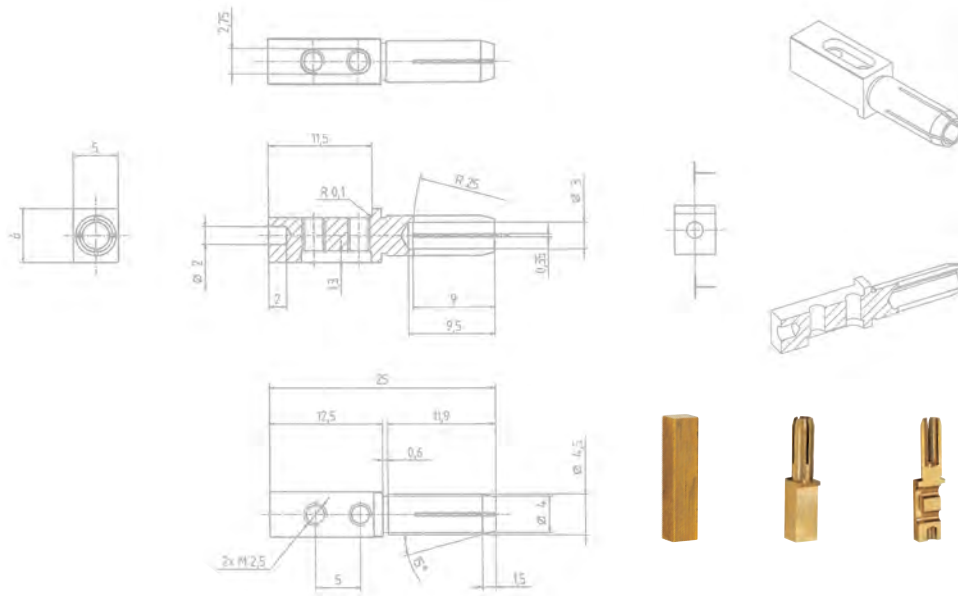

From blank to completely machined workpiece (on the right a cutaway view)



4  
Final turning



5  
Chamfering



8  
Sideways milling



9  
Sideways drilling and thread cutting

## Versatility

# Multistar Superstar !

Multistar does not shy away from difficult machining. Demanding tasks such as deep-hole drilling to a bore depth of  $30 \times D$  are not a problem. Does your workpiece require complicated milling operations? No problem! Multistar NX-24 "chips" any required milling contour.

Even more: The workpieces that come off the turntable are ready for installation, thanks to de-burring and checking processes.

### Multistar machining variations to catch your eye

- Simultaneous dual sided machining
- Drilling
- Milling
- Deep-hole drilling
- Thread cutting
- Complex grooving

... all with mechanical or CNC controlled units and all of this in any arbitrary position. With Multistar you have a competent, reliable and very cost effective multi talented partner at your side. Bring your products into the limelight, put them on Multistar, the Superstar!



Loading from feed belt



Off-center pre-drilling



Off-center drilling



Drilling a calotte

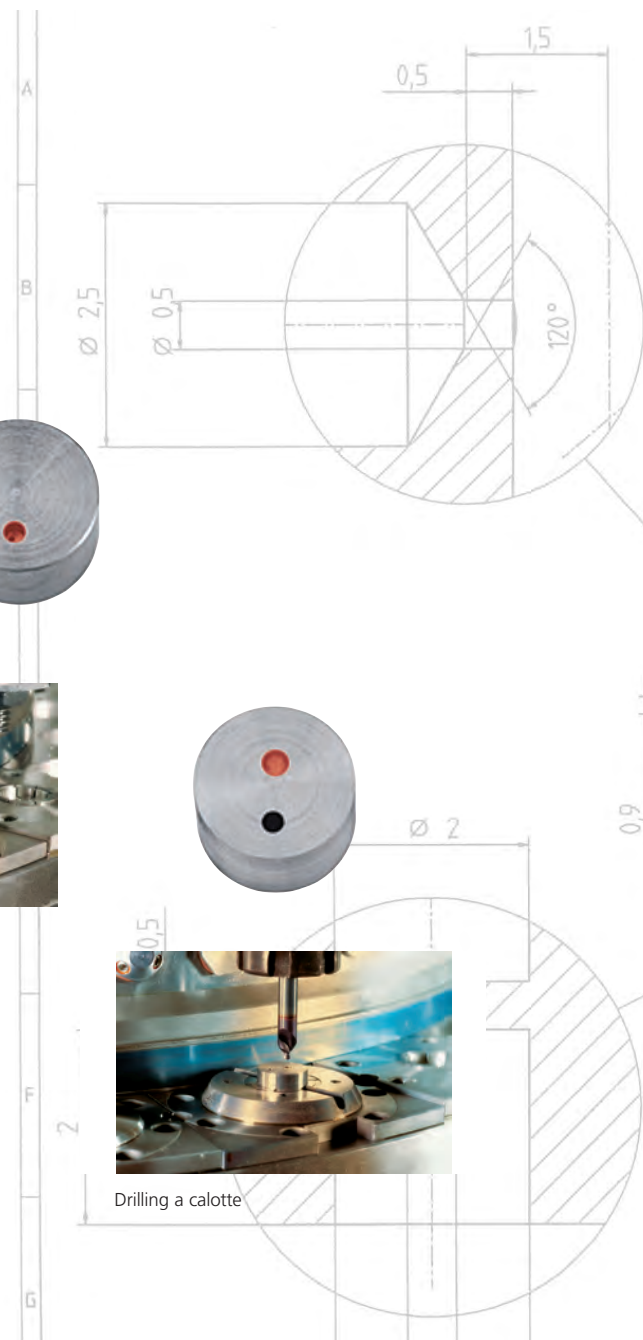



Cutaway view of a workpiece with Mikron Tool cutting tools

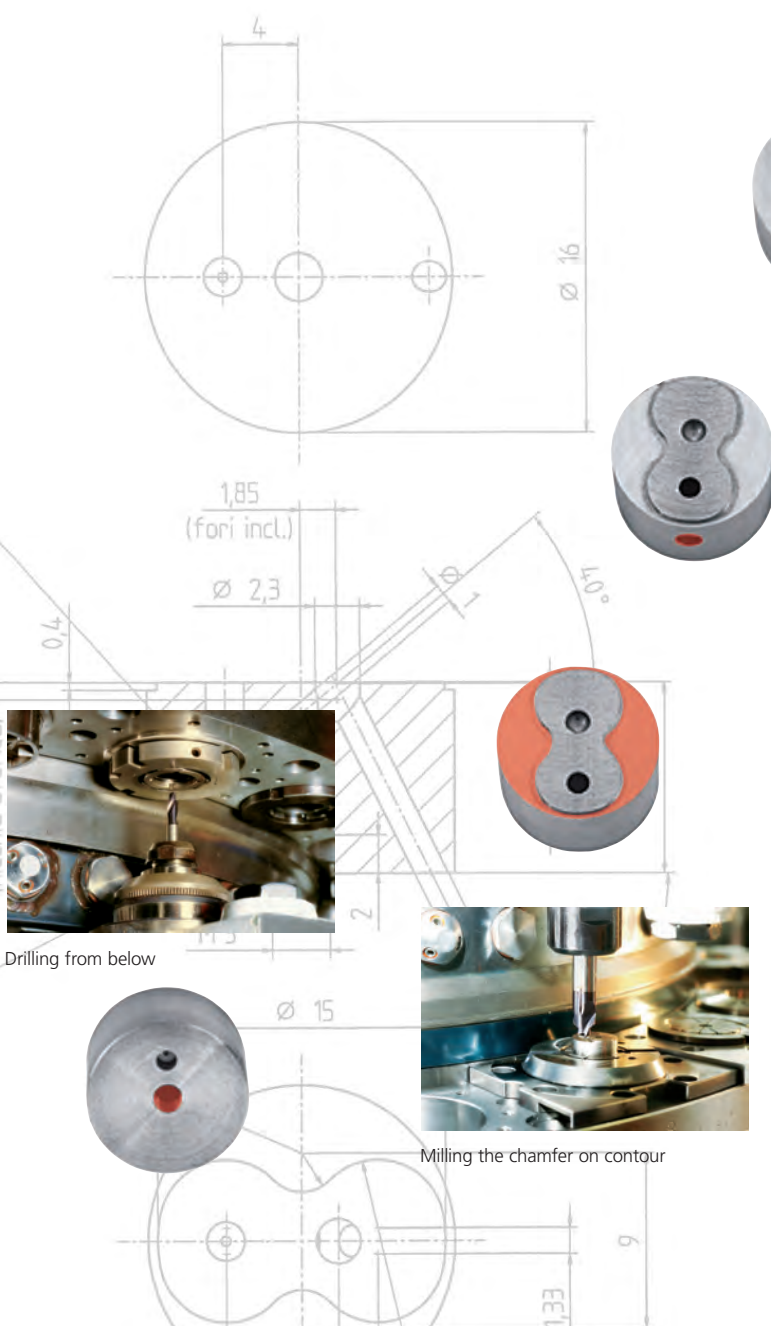

Inclined deep-hole drilling from below



Inclined deep-hole drilling from above



Sideways drilling



Drilling from below



Milling the chamfer on contour

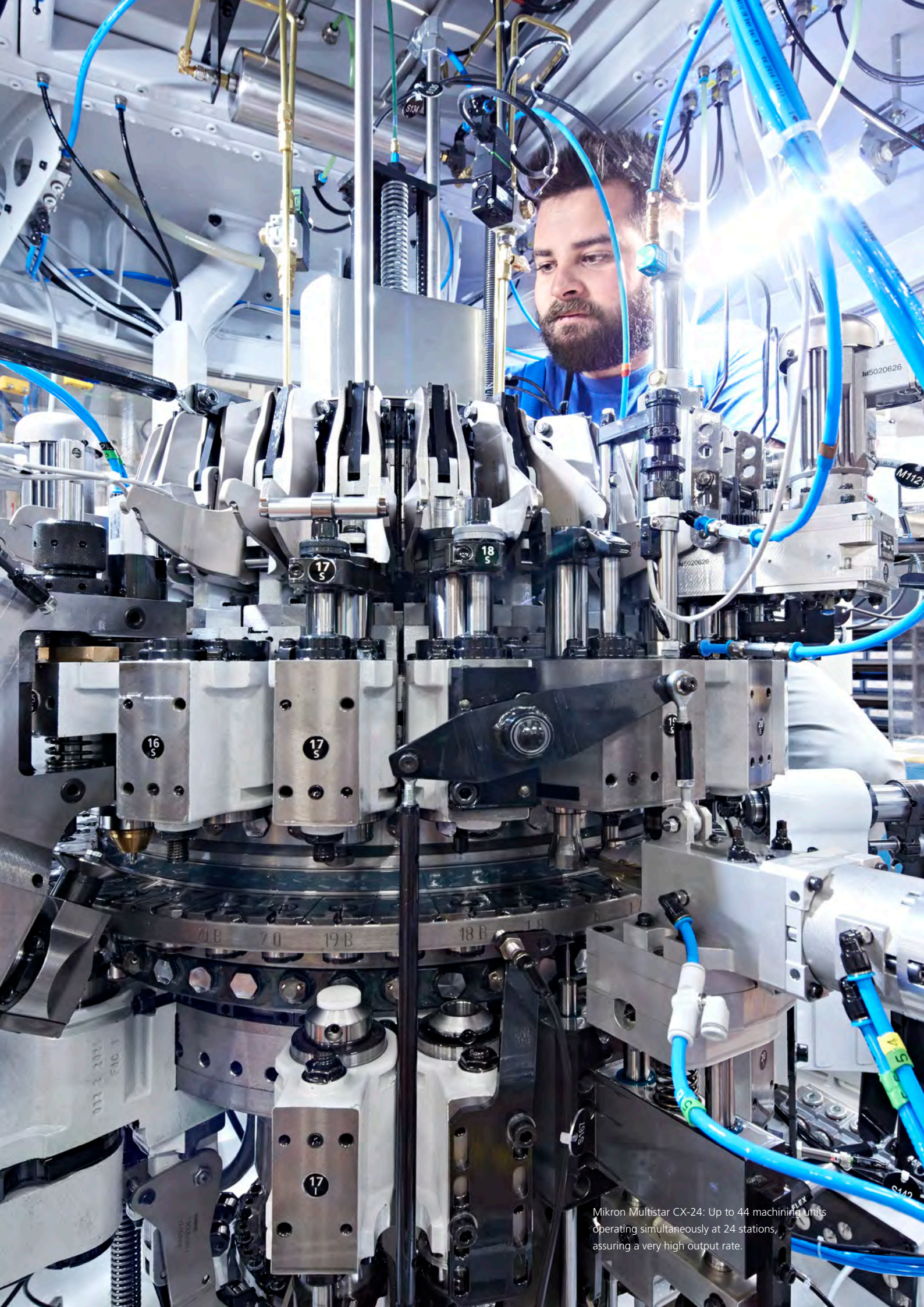

Mikron Multistar CX-24: Up to 44 machining units operating simultaneously at 24 stations, assuring a very high output rate.

# Mikron Service Solutions

flexible and modular

We ensure quick, competent and uncomplicated service and support for our customers. We work together with you to design a service solution profile tailored to your individual needs.

## Mikron's service palette:



### Spare Part Service

#### For a dependable supply of spare parts

Genuine Mikron spare parts are manufactured to the latest materials specifications and by the latest methods, resulting in reduced machine downtime and a longer life expectancy for your equipment.



### Xchange Service

#### Minimizing downtime

Original Mikron Xchange Modules are ready for immediate installation. 100% reliability and 100% quality, but at up to 50% lower investment and without losing any time waiting for an overhaul. All you need to do is call us when you need to replace a defective module, and we'll immediately send a replacement module in perfect condition.



### Product Support

#### Maintain your equipment

Service options from Product Support keep your Mikron system in top condition. Our highly skilled experts offer you a complete portfolio of comprehensive service options to keep your equipment up and running.

[Help Desk](#) / [Field Service](#) / [Overhaul](#) / [Preventive Maintenance](#) / [Teleservice](#)



### Business Support

#### Guarantee continuous use of your investment

Mikron offers professional services based on our experience and resources to help you successfully manage today's complex manufacturing processes...

[Training Services](#) / [Retooling](#)

## Global Support

Ready for you

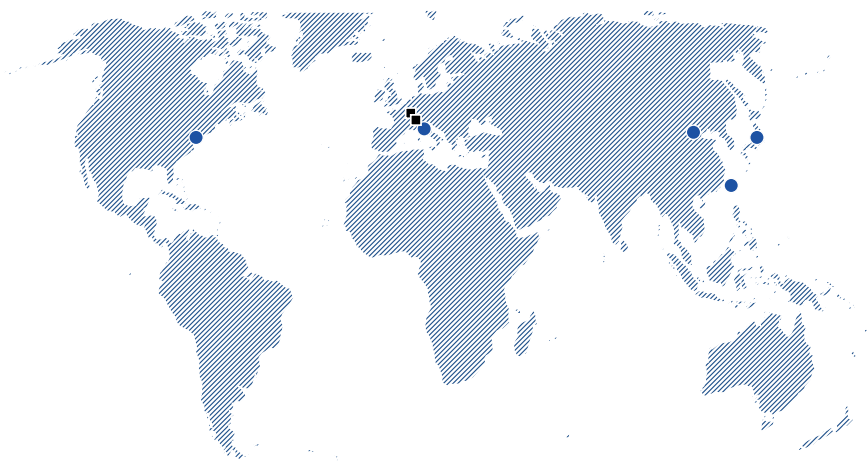

#### 24h Global Serviceline

+41 91 610 63 26

Al di fuori degli orari di ufficio.

Comunicazione di problemi 24 ore su 24.

■ Production sites  
Switzerland, Agno; Germany, Rottweil

● Strategic partnership or presence

**MIKRON**

## Mikron Machining

### **Mikron Switzerland AG, Agno Division Machining**

Headquarter  
Via Ginnasio 17  
6982 Agno  
Switzerland  
Tel. +41 91 610 61 11  
Fax +41 91 610 66 80  
mag@mikron.com

### **Mikron Germany GmbH**

Berner Feld 71  
D-78628 Rottweil  
Tel. +49 741 5380 0  
Fax +49 741 5380 580  
mro@mikron.com

### **Mikron Corp. Monroe**

200 Main Street  
P.O. Box 268  
Monroe, CT 06468 / USA  
Tel. +1 203 261 31 00  
Fax +1 203 268 47 52  
mmo@mikron.com

