

Mikron's World



Highly Efficient
Machining Solutions



CONTENTS

Electric, Electronics & Infocom	6
Case History	12
Automotive	16
Case History	30
Watch Industry	34
Hydraulic and Pneumatic	40
Bicycle	46
Case History	49
Household Goods	50
Case History	53
Medical	54
Writing	56
Machining Systems	62
Mikron miTool	68
Case History	70

Machining Systems

Efficient production solutions

High performance turnkey production solutions from A to Z to enable productivity and quality gains in the manufacturing processes of our customers.

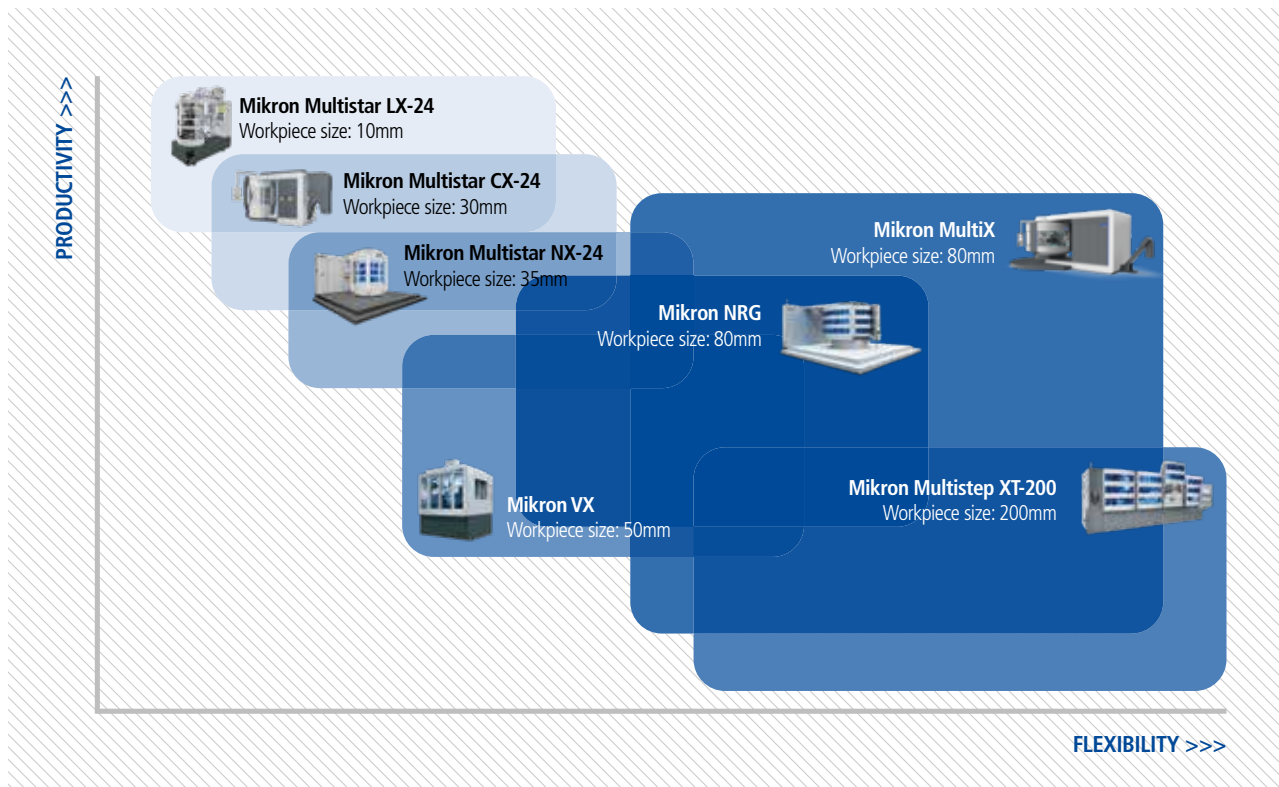

With over 100 years of experience, rooted in Swiss innovation and quality culture, we are a long term process and technology partner to industry leaders. We show passion for precision and reliability in all we do.

Blank	Pre-machining	Loading Systems	Machining	Unloading Systems
<ul style="list-style-type: none"> » Cast » Bar » Wire » etc. 	<ul style="list-style-type: none"> » Mikron RP-32 » Mikron TR-42 » Mikron TF-120 	<ul style="list-style-type: none"> » Pick & Place » Robot » Belt conveyor » Vibrator » Pallet 	<ul style="list-style-type: none"> » Precise complete machining on Mikron systems » Dedicated Mikron cutting tools 	<ul style="list-style-type: none"> » Automatic » Manual » Deburring » Washing

Customized high-performance machining solutions with:

- » Loading and unloading system
- » Pre-processing system
- » Dedicated Mikron cutting tools

Mikron Machining

Mikron Machining is the leading supplier of high performance machining systems which enable productivity and quality gains in the manufacturing processes of our customers.

Mikron's high performance machining systems and solutions support industrial production companies in a wide variety of sectors by reducing unit costs, space requirements and staffing costs, and by increasing manufacturing quality. Mikron's ultimate goal is to enable its customers to improve their production processes, product quality and profitability. With its gear-cutting machines and tools, Mikron, a company rooted in the Swiss culture of innovation, contributed significantly to the industrialization of Swiss watchmaking in the first half of the last century. Today, Mikron markets machining solutions for the highest precision manufacturing processes, supported by digital services and technologies. Pro-active and long-term customer services supplement the high-tech offering.

Highly productive transfer systems for the manufacturing of complex high-precision components made of metal such as turbocharger housings, injection nozzles and ballpoint pen tips.



ELECTRIC, ELECTRONICS & INFOCOM

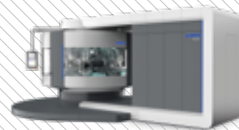

Mikron offers the best solutions for maximum piece rates in the electric/electronic industry, including electronic/electrical contacts, connector shells, and accessories, even where a large number of operations per piece are required.

Mikron high-precision rotary transfer solutions ensure:

- » Very high output, up to 28,000 pieces/hour
- » Process efficiency, from 8 to 24 stations
- » Impressive cost per part savings
- » Precise deburring of workpieces
- » Ability to machine entire parts in a single operating cycle
- » Ability to machine directly from wire

High-performance machining solutions from Mikron Machining enable our customers to set new production standards for many different applications such as:

- » Electronic components
- » Connectors
- » Plugs, sockets
- » Housings
- » Computer (hard disk cases, IC connectors, read/write head arms for hard disk drives)
- » Fiber optics
- » E-mobility connectors

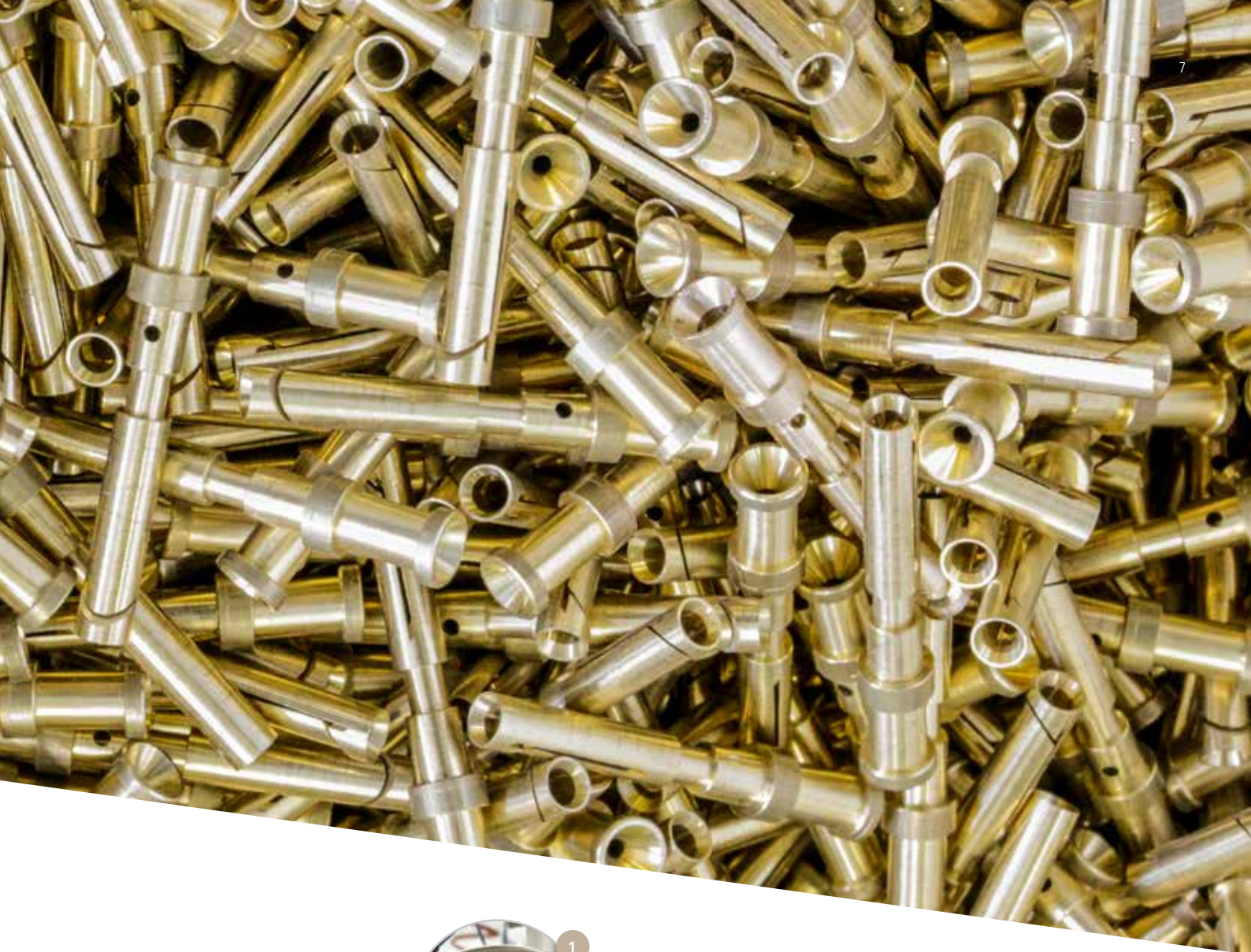

Mikron transfer machines for the cost efficient and high volume production of precision parts.



Renowned suppliers in the electric/electronic industry trust our extensive experience in high volume workpiece manufacturing.

ELECTRICAL CONNECTORS



Ø 5 mm
L 10 mm

Fiber Optic Ferrule

Stainless steel
50 pcs/min on Mikron Multistar LX-24



Ø 7 mm
L 12 mm

Contact Bushing

Brass
50 pcs/min on Mikron Multistar CX-24



Ø 4 mm
L 9 mm

Neon Pin

Brass
520 pcs/min on Mikron Multistar LX-24

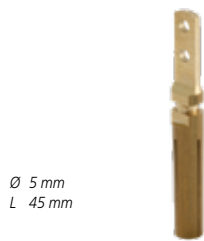

Ø 5 mm
L 45 mm

Connector

Brass
50 pcs/min on Mikron Multistar CX-24

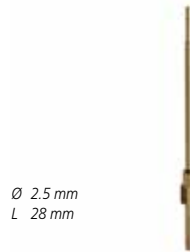

Ø 2.5 mm
L 28 mm

Connector Pin

Brass
36 pcs/min on Mikron Multistar LX-24

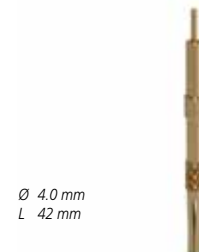

Ø 4.0 mm
L 42 mm

Connector Pin

Brass
50 pcs/min on Mikron Multistar LX-24



Ø 5 mm
L 45 mm

Connector Pin

Brass
50 pcs/min on Mikron Multistar CX-24



7.2 x 4.3 x 31.8 mm

Connector Pin

Brass
120 pcs/min on Mikron Multistar LX-24

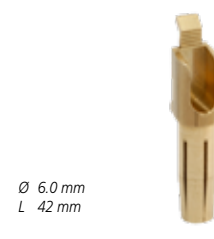

Ø 6.0 mm
L 42 mm

Connector Socket

Brass
35 pcs/min on Mikron Multistar CX-24



8 x 8 x 28 mm

Connector Pin

Brass
35 pcs/min on Mikron Multistar CX-24



7 x 8 x 30 mm

Connector Socket

Brass
50 pcs/min on Mikron Multistar LX-24



Ø 5.0 mm
L 24 mm

Connector Socket

Brass
50 pcs/min on Mikron Multistar CX-24

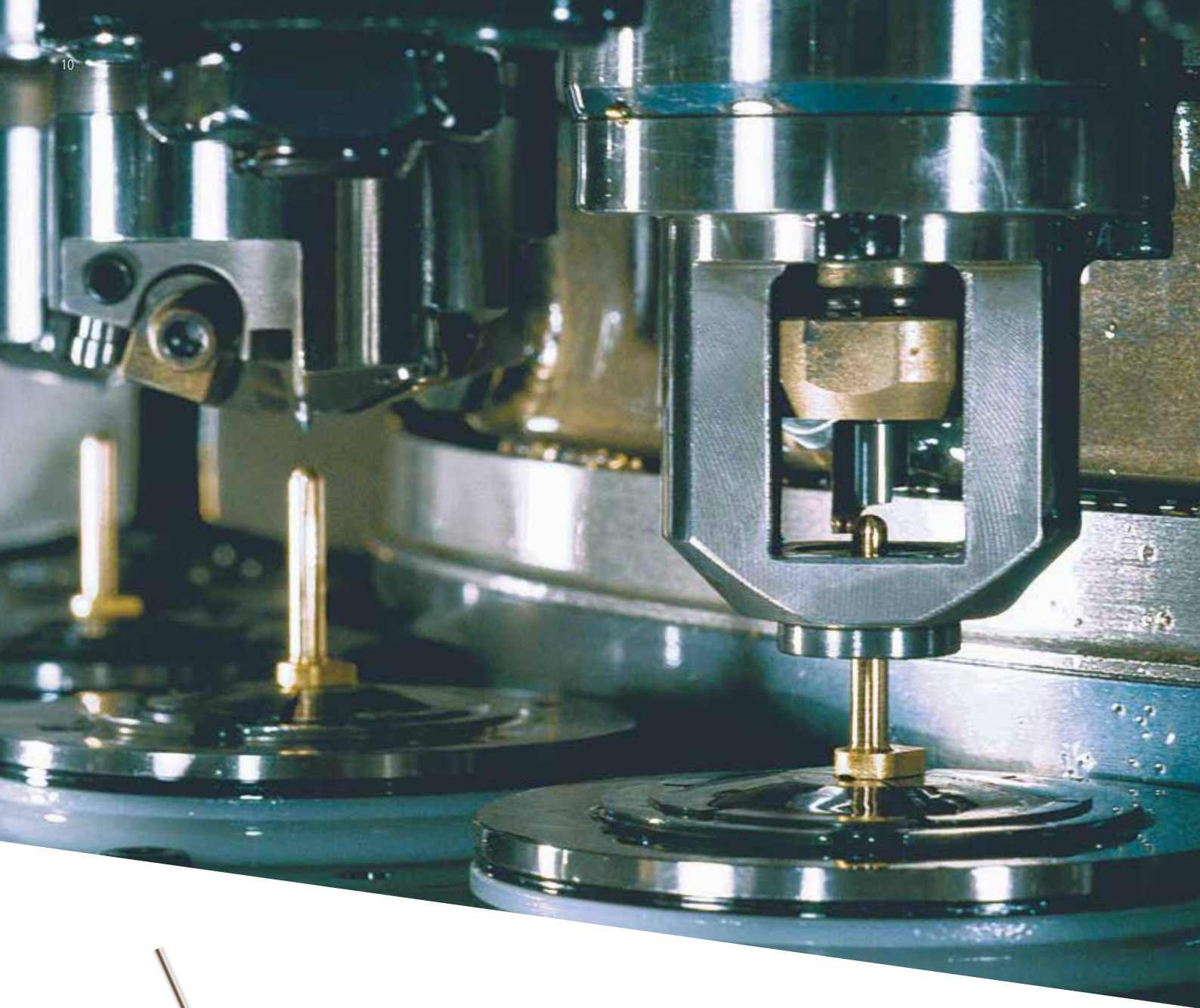

Mikron Multistar can be equipped with an advanced bushing guide system that holds the part near the cutting tool during the turning operations, assuring high precision, no vibrations, and perfect surface finish for very challenging Diameter/Length ratio (70xD); example $\text{\O} 0.5\text{mm}$ length 36mm

Thanks to the 24 stations and up to 44 cutting tools simultaneously in action, Mikron Multistar enables the simultaneous production of pins and sockets on the same machine simplifying the logistic, less warehouse space and enables the just-in-time delivery. Eliminating the changeover step saves time and increases the number of production hours per year, which lowers the hourly cost.

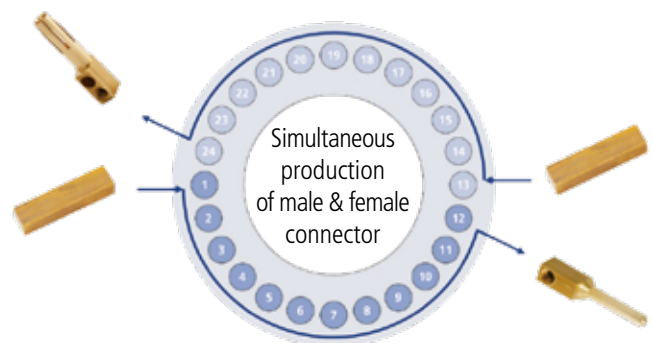

ELECTRICAL CONNECTORS



9 x 9 x 20 mm

Electro Clamp

Brass

160 pcs/min on Mikron Multistar LX-24



8 x 8 x 14 mm

Connector

Brass

140 pcs/min on Mikron Multistar LX-24



8 x 8 x 28 mm

Connector Pin

Brass

35 pcs/min on Mikron Multistar CX-24



Ø 1.5 mm
L 2.3 mm

Pogo Pin

Brass

140 pcs/min on Multistar LX-24



Ø 4.0 mm
L 26 mm

Connector Pin

Brass

140 pcs/min on Mikron Multistar LX-24



Ø 6.5 mm
L 28 mm

E-mobility Connector

Brass

50 pcs/min on Multistar CX-24



Ø 0.5 mm
L 36 mm

Special Connector

Brass

25 pcs/min on Multistar CX-24



Ø 4.5 mm
L 30 mm

Connector Pin

Brass

50 pcs/min on Mikron Multistar CX-24



6 x 7 x 28 mm

Connector Pin

Brass

160 pcs/min on Mikron Multistar LX-24



Ø 4.0 mm
L 33 mm

Connector

Brass

55 pcs/min on Mikron Multistar CX-24



Ø 9 mm
L 32 mm

Locking Contact

Brass

10 pcs/min on Multistar NX-24

NEW standard machining solution for pin & socket with extra benefit Mikron Multistar CX-24^{CONTACTS}



Mikron Multistar CX-24^{CONTACTS}

maximum performance with a NEW standardized machining solution suited for the most requested contact typologies and types.

**YOUR EXTRA BENEFIT
SIGNIFICANT DELIVERY TIME REDUCTION**

SEND US YOUR DRAWING!

We will check if your contact is qualified for the new Mikron Multistar CX-24^{CONTACTS} and send you an unbeatable quotation.

4 TYPICAL EXAMPLES OF SUITABLE CONTACTS:



60 or 120*
pcs/min



50 or 100*
pcs/min

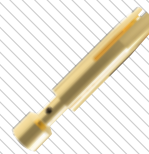

55 or 110*
pcs/min



50 pcs/min

scale 1:1

* Double cycle

TYPICAL CASE HISTORY Socket

On Mikron Multistar CX-24



The challenge

- » **High Volume production of approx. 12 million pieces/year**
- » Part Dimension: Ø 2.54mm L 15mm
- » Raw material (brass) supply from wire coil
- » Approximately 20 operations such as turning, milling, drilling, reaming, deburring, forming, 100% extraction force measurement integrated in the process
- » Tolerances: External Ø (turned) ±0.01mm, Internal Ø (reamed) ±0.01mm, length between machined surfaces ±0.02mm



UP-SIDE DOWN

Exclusivity Mikron: the part is flipped-over and fixed in an alternative collet, in a different section-shape, for the machining of the other side of the part.

The traditional solution

Production area:
136.2 m²



Required machines:
16



Employees:
3.2 + 3.2 + 3.2



Cost/part



Raw material from bar-stock

Mikron: The innovative solution

Production area:
38.64 m²



Required machines:
1 Mikron Multistar CX-24 & 1 Mikron TF-120



Employees:
0.5 + 0.5 + 0.5

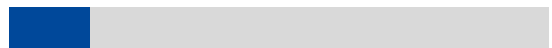

Cost/part



Raw material from wire coil

Your advantage

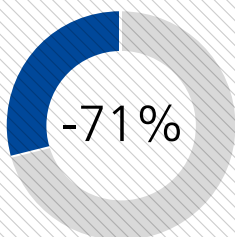

Production area

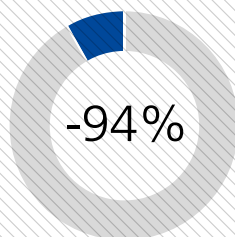

Machines

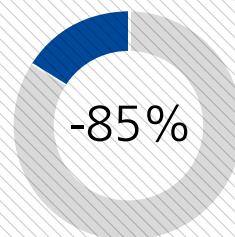

Employees

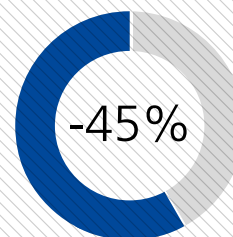

Cost/part

600

**PARTS PER MINUTE
MACHINING RATE
OUR SYSTEMS
CAN REACH**



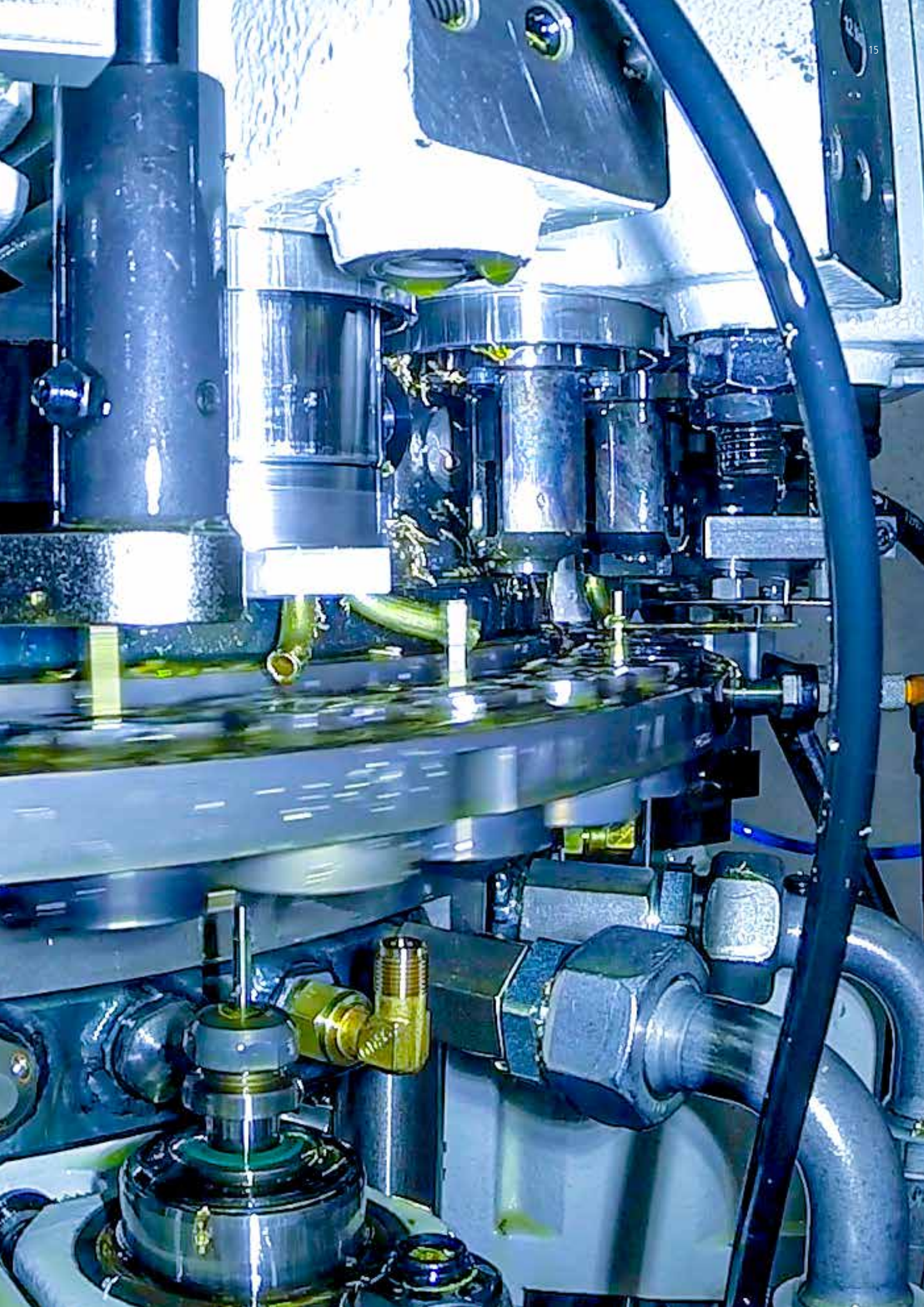

AUTOMOTIVE



Mikron's high performance machining systems and solutions support automotive production companies in a wide variety of applications by reducing unit costs, space requirements and staffing costs, and by increasing manufacturing quality.

With our portfolio of high-precision transfer systems and cutting tools, we fully meet the stringent demands of the automotive industry for accuracy, quality, complex operations and flexibility.

Product lines include

- » Parts for EV vehicles
- » Injector bodies
- » Diesel nozzle holders
- » Rocker arms
- » Pistons for ABS brakes
- » Expansion valves and throttle valve shafts
- » Etc.

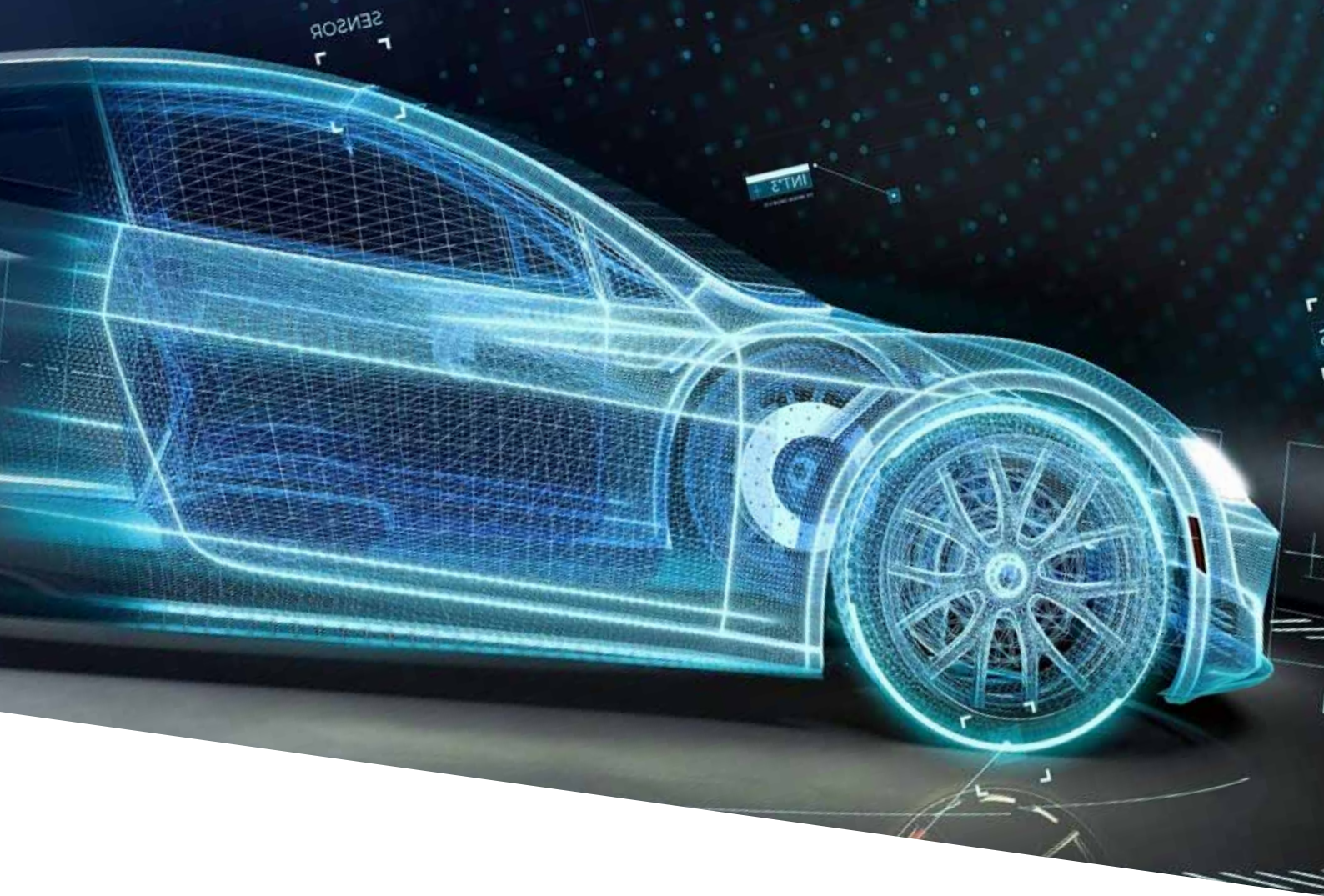

We support automotive customers to achieve and maintain a leading position in the market, by achieving productivity and quality gains in the manufacturing processes.

Amongst them are:

CATERPILLAR[®]

 **BOSCH**

DOOWON

Delphi
Technologies

 **Stanadyne**
Fueling Innovation

TRW

MIKRON



Mikron Machining systems adapt perfectly to the rapid change of the automotive industry. E-Cars are reusing some components of the combustion engine model, while the drive is completely electric.

ELECTRIC VEHICLE COMPONENTS

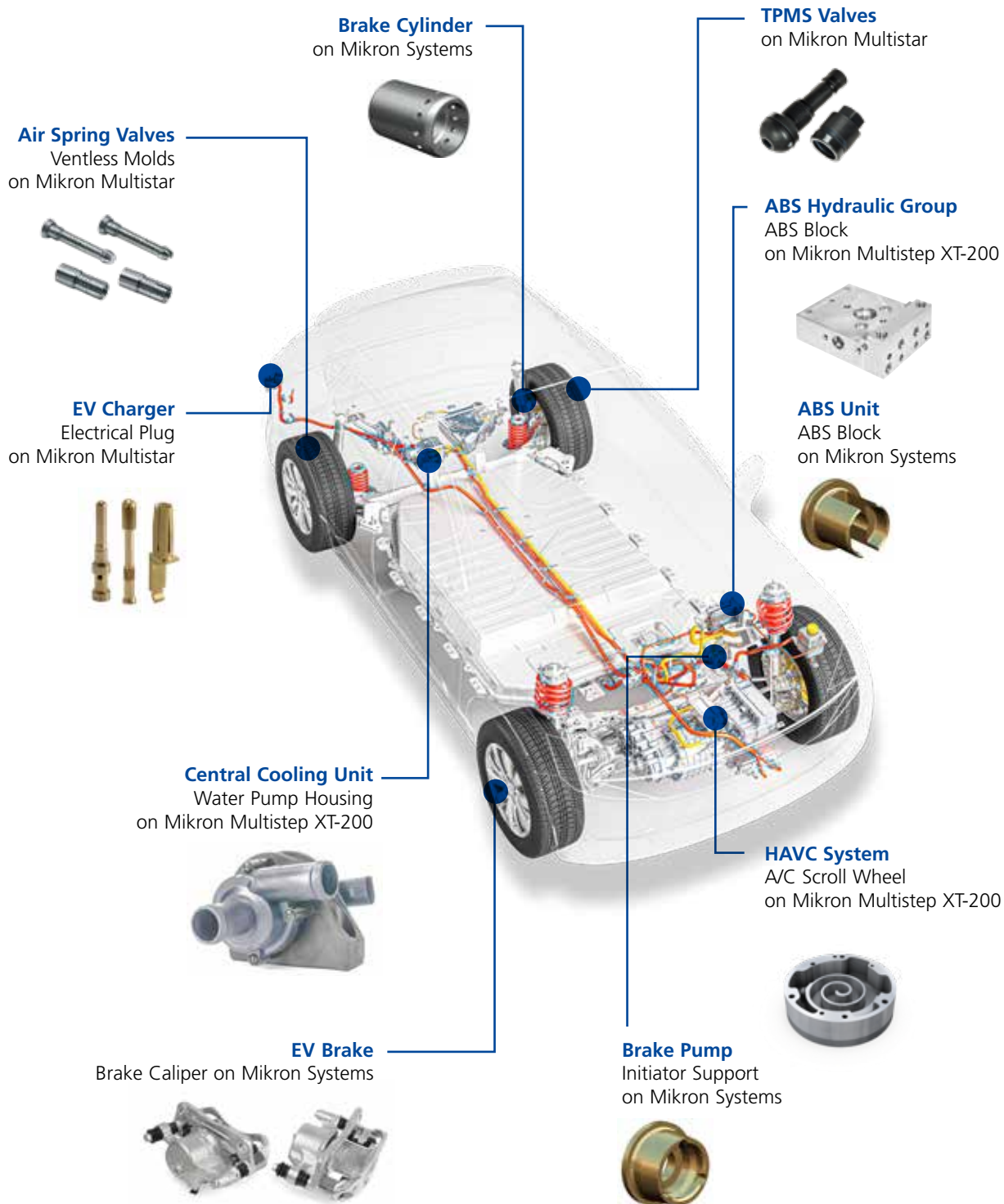



Where high volumes are required a double cycle offers particular advantages for cost reduction. Complete machining in one single clamping starting from a cut-off profile is also possible. All operations are performed meeting the high technical requirements in respect to accuracy and quality.

AIR CONDITIONING COMPONENTS



Compressor Housing
on Mikron Multistep XT-200



Compressor Piston
on Mikron Systems



Expansion Valve
on Mikron Systems



Service Valve
on Mikron Systems



Holder
on Mikron Systems



Sleeve
on Mikron Systems



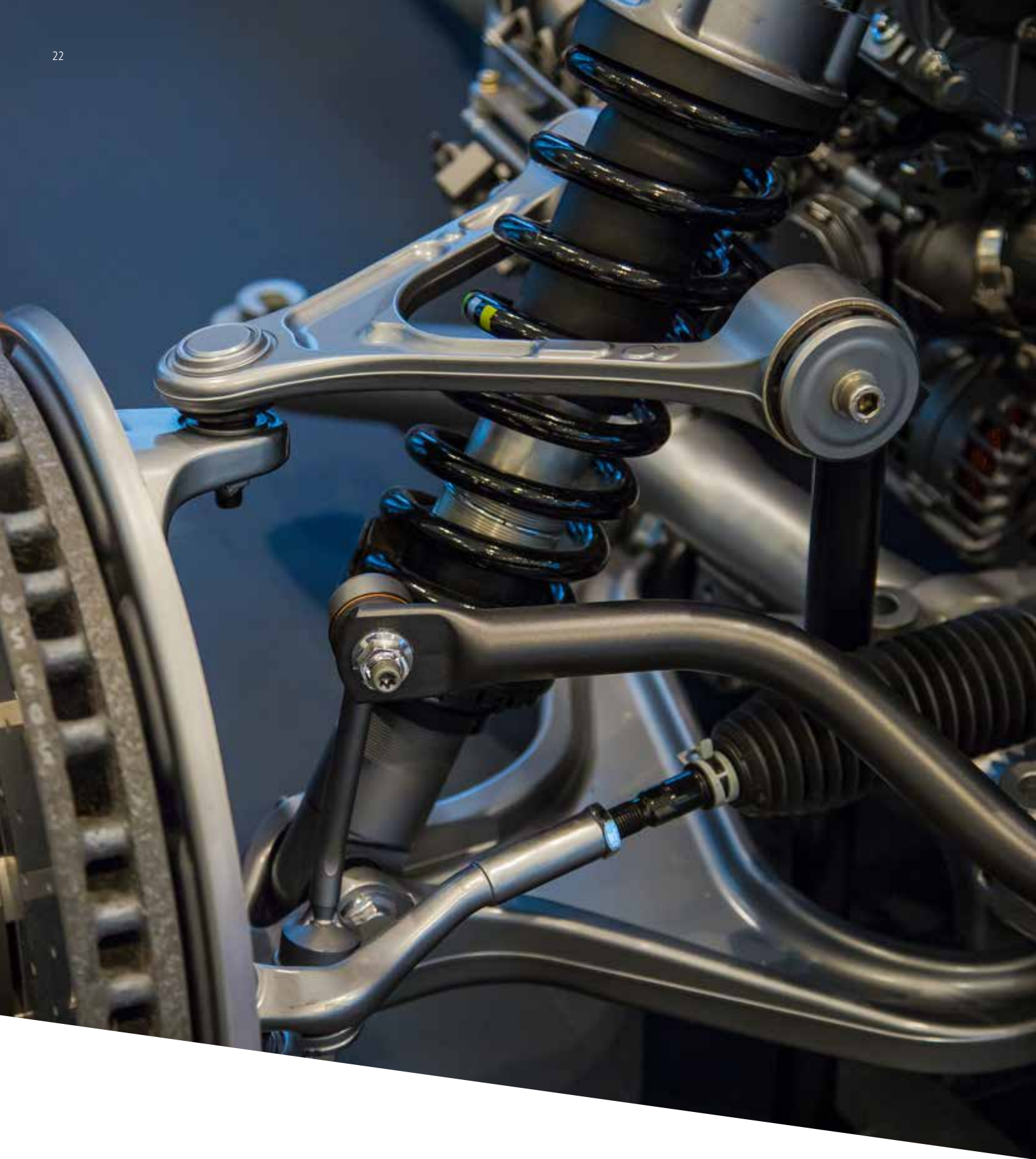

With our portfolio of high-precision transfer systems and cutting tools, we fully meet the stringent demands of the automotive industry for accuracy, quality, complex operations and flexibility.

BRAKE, SAFETY & STEERING COMPONENTS



ABS Brake
on Multistar CX-24



ABS Valve
on Mikron Multistep XT-200



Drum Brake Cylinder
on Mikron Multistep XT-200



Tandem Brake Pump
on Mikron Multistep XT-200



Air Dryer Modul
on Mikron Multistep XT-200



ABS Housing
on Mikron Multistep XT-200



Steering Fork
on Mikron Systems



Steering Fork
on Mikron Multistep XT-200



Steering Sleeve
on Mikron Systems



Steering Gear
on Mikron Systems



Steering Housing
on Mikron Multistep XT-200



Steering Gear Pump Body
on Mikron Multistep XT-200



Mikron has been building transfer machines to produce components for diesel injection systems for over 30 years. Accuracy, quality, complexity of operations, flexibility, whichever characteristics are required for your various components, there is a Mikron machining system to give you the most practical production process.

INJECTION COMPONENTS



Nozzle Body
on Multistar NX-24



Spring Holder
on Mikron Systems



Injection Body
on Mikron Multistep XT-200



Injection Valve
on Multistar NX-24



Guide for Fuel Injection
on Multistar CX-24



Valve Body
on Mikron NRG



High Pressure Fuel Pump
on Mikron Multistep XT-200



GDI Pump Housing
on Mikron MultiX



Piston Guide
on Multistar NX-24



Distributor for Fuel Injection
on Multistar NX-24



Valve Insert
on Multistar NX-24



Accumulator
on Multistar NX-24

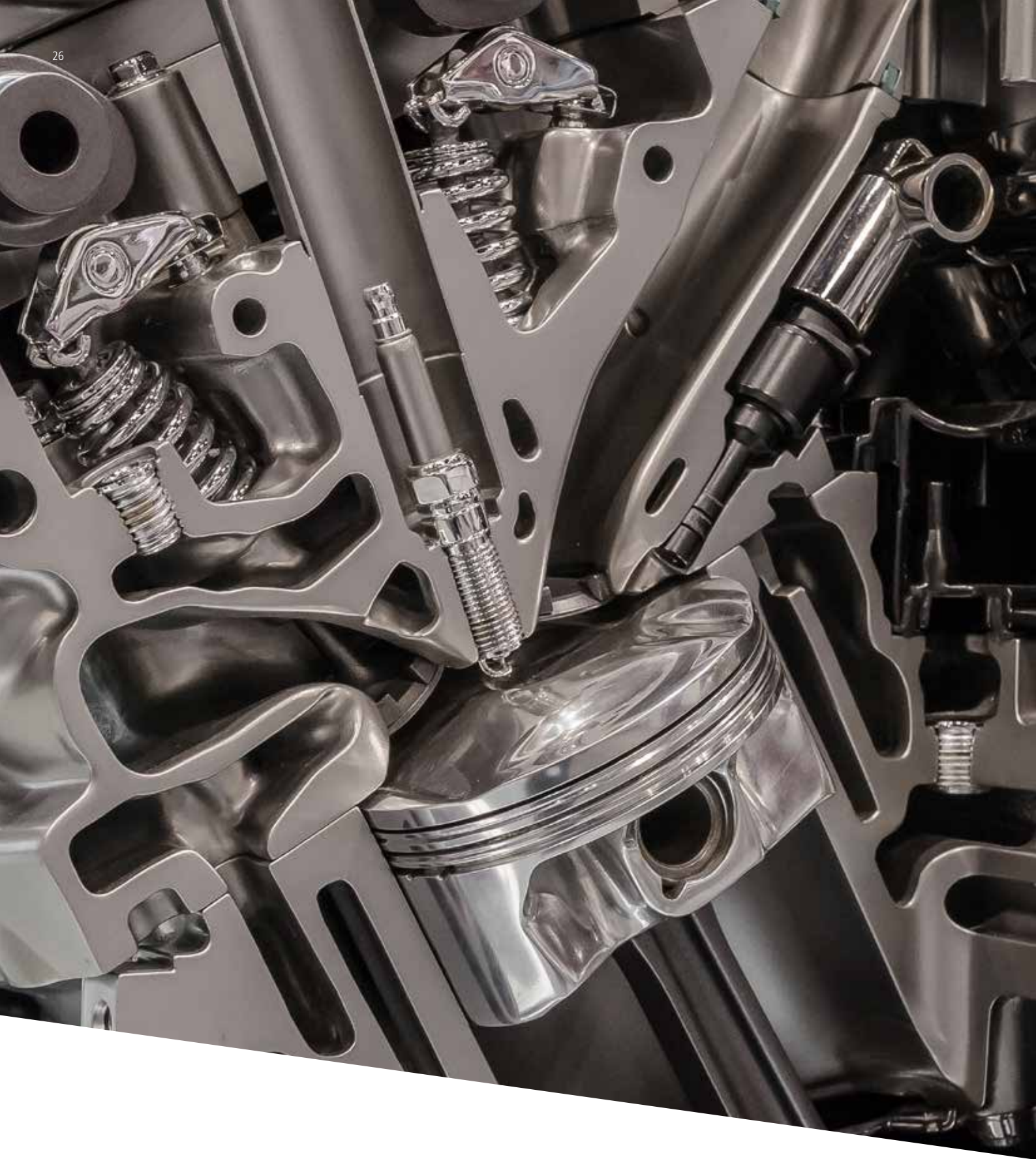

Mikron machines have been supplied Worldwide to all the major engine components manufacturers. An experience of over 30 years in this particular field is the basis for machine design, working procedure and cutting tools.

ENGINE COMPONENTS



Housing
on Mikron Multistep XT-200



Distributor Shaft
on Mikron Systems



Rocker Arm
on Mikron Multistep XT-200



Throttle Body
on Mikron Multistep XT-200



Rocker Arm
on Mikron Multistep XT-200



Cam Bracket
on Mikron Multistep XT-200



Pump Housing
on Mikron Multistep XT-200



Oil Pump Housing
on Mikron Multistep XT-200



Housing
on Mikron Multistep XT-200



Throttle Shaft
on Mikron Systems



First class machining systems for Lowest cost per part!
Efficient compressor housing machining in exceptionally
high quality with Mikron machining systems.

TURBOCHARGER COMPONENTS



Impeller Wheel
on Mikron Multistep XT-200



Compressor Housing
on Mikron Multistep XT-200



Bearing Housing
on Mikron Multistep XT-200



VGT blade Holder
on Mikron Systems



Turbine Housing
on Mikron Multistep XT-200



CASE HISTORY

Automotive Components

On Mikron Multistar LX-24



The challenge

- » Double the annual production from 14 to 26 million parts/year while reducing the cost/part by 30%
- » No increase of floor space possible. With the actual production method (single spindle cam driven lathes) 77m² are occupied
- » Production in 3 shifts
- » Raw material: SUS303 (X8CrNi319-9) from wire Ø 4 mm
- » Tolerances: on Ø ± 6 µm Cmk1.67, radial run-out 6µm Cmk1.67

The traditional solution

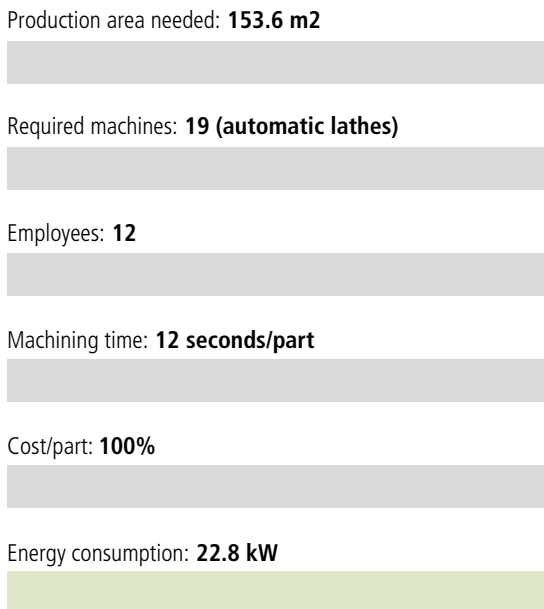

Mikron: The innovative solution

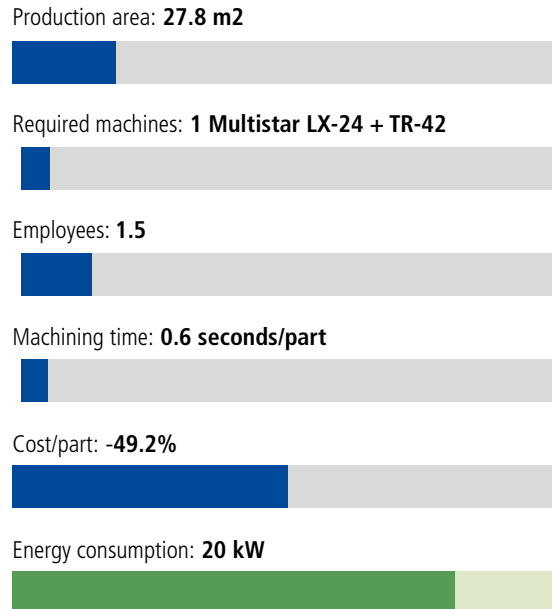

Your advantage

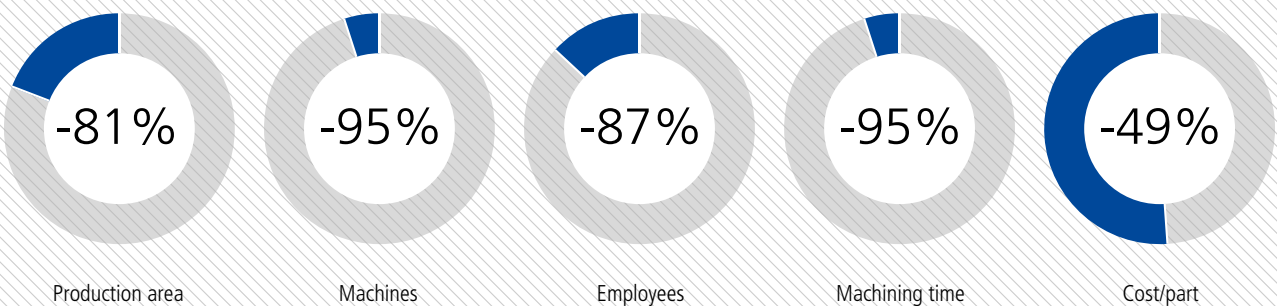

CASE HISTORY Air Spring Valves (Ventless Molds)

On Mikron Multistar CX-24



The challenge

- » **30+30 million parts per year**
- » 2 pieces made in steel, with turning, drilling & milling operations
- » Production of male & female component simultaneously on the same machine
- » Tolerances: $\pm 10\mu\text{m}$ on diameters
- » Raw material supply from wire coil (instead from bar-stock)



The traditional solution

Production area: **136.2 m²**



Required machines: **16**



Employees: **3.2 + 3.2 + 3.2**



Cost/part



Raw material from bar-stock

Mikron: The innovative solution

Production area: **38.64 m²**



Required machines: **1 Mikron Multistar CX-24**



Employees: **0.5 + 0.5 + 0.5**



Cost/part



Raw material from wire coil

Your advantage

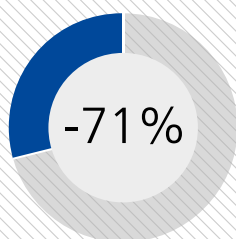

Production area

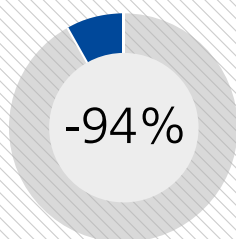

Machines

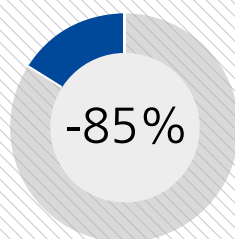

Employees

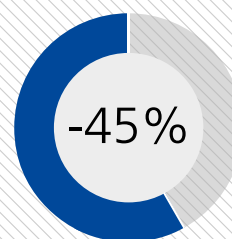

Cost/part



10'000'000

**AUTOMOTIVE PARTS
MACHINED DAILY
ON MIKRON SYSTEMS
WORLDWIDE**



CAUTION!
Do not touch moving parts or components of the machine while it is running. To avoid injury, do not touch the workpiece or the tool while the machine is running.

Z00

Y+

WATCH INDUSTRY

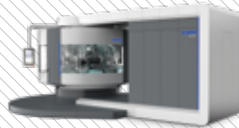

Mikron Machining Systems: Ideal solutions for the watchmaking industry. Modern production of watch components requires machining systems which offer high output, accuracy, flexibility and perfect surface finish. The state-of-the-art designed Mikron Machining Systems are the perfect answer to meet all the requirements for the economical production of watch plates and bridges, and a wide range of watch bracelet components, cases, crowns and screws.



WATCH BRACELET COMPONENTS

Requirements

- » Machining of family of parts
- » Variable lot sizes
- » High accuracy and surface finish

WATCH PLATES AND BRIDGES

Requirements

- » High flexibility
- » High accuracy & surface finish
- » Reliable repeatability
- » Big volumes

WATCH CASES

Requirements

- » Machining of family of parts
- » Variable lot sizes

WATCH SCREWS AND CROWNS

Requirements

- » Machining of small parts in very high volume
- » High accuracy



**Mikron Machining Systems:
Ideal solutions for
the watchmaking industry**

- » High flexibility
- » High accuracy & surface finish
- » Reliable repeatability
- » Big volumes
- » Machining of family of parts
- » Variable lot sizes
- » Machining of small parts
in very high volume

WATCH COMPONENTS



Watch Plate
Brass, on Mikron NRG



Watch Bridge
Brass, on Mikron NRG



Watch Bridge
Brass, on Mikron NRG



Watch Bridge
Brass, on Mikron NRG



Bracelet Link
Titanium, on Mikron VX



Bracelet Link
Titanium, on Mikron NRG



Bracelet Link
Stainless steel, on Mikron VX



Bracelet Link
Gold alloy, on Mikron VX



Bracelet Link
Stainless steel, on Mikron VX



Watch Case
Stainless steel,
on Mikron Multistep XT-200



Watch Crown
Gold alloy, on Mikron Multistar



Watch Screw
Stainless steel, on Mikron Multistar



A close-up photograph of a precision-machined metal component, likely a part of a machine tool. The component is cylindrical with a central hole and is surrounded by other metal parts. The background is blurred, showing a factory or workshop environment.

$\pm 0.002\text{mm}$

**MACHINING PRECISION
ON OUR MACHINES**

HYDRAULIC & PNEUMATIC

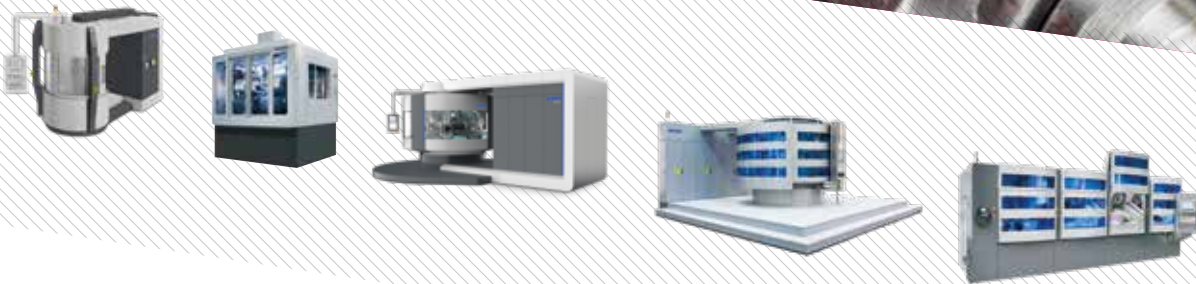

Machining high-quality components for the pneumatic and hydraulic industry requires high-performance machining systems. Operations such as drilling, milling, turning, threading and deburring, all on the same part, must be performed flexibly to produce different components at maximum capacity.

Successful applications on Mikron machining systems in the hydraulic and pneumatic fields cover a wide range. Typical examples are:

- » High-pressure processing
- » Hydraulic and pneumatic cylinders
- » Vehicle and industrial hydraulics
- » Solenoid and industrial hydraulics
- » Proportional and control valves
- » Pumps
- » Systems engineering



Mikron Machining offers the best machining solution to perform all of these operations with a single clamping step.

Market leaders worldwide are for years relying on Mikron machining systems to improve quality of their machined parts while reducing the cost per part at the same time.

References:

BUCHER
hydraulics

CAMOZZI
Automation

FESTO

Humphrey

 **NORGREN**



rexroth
A Bosch Company



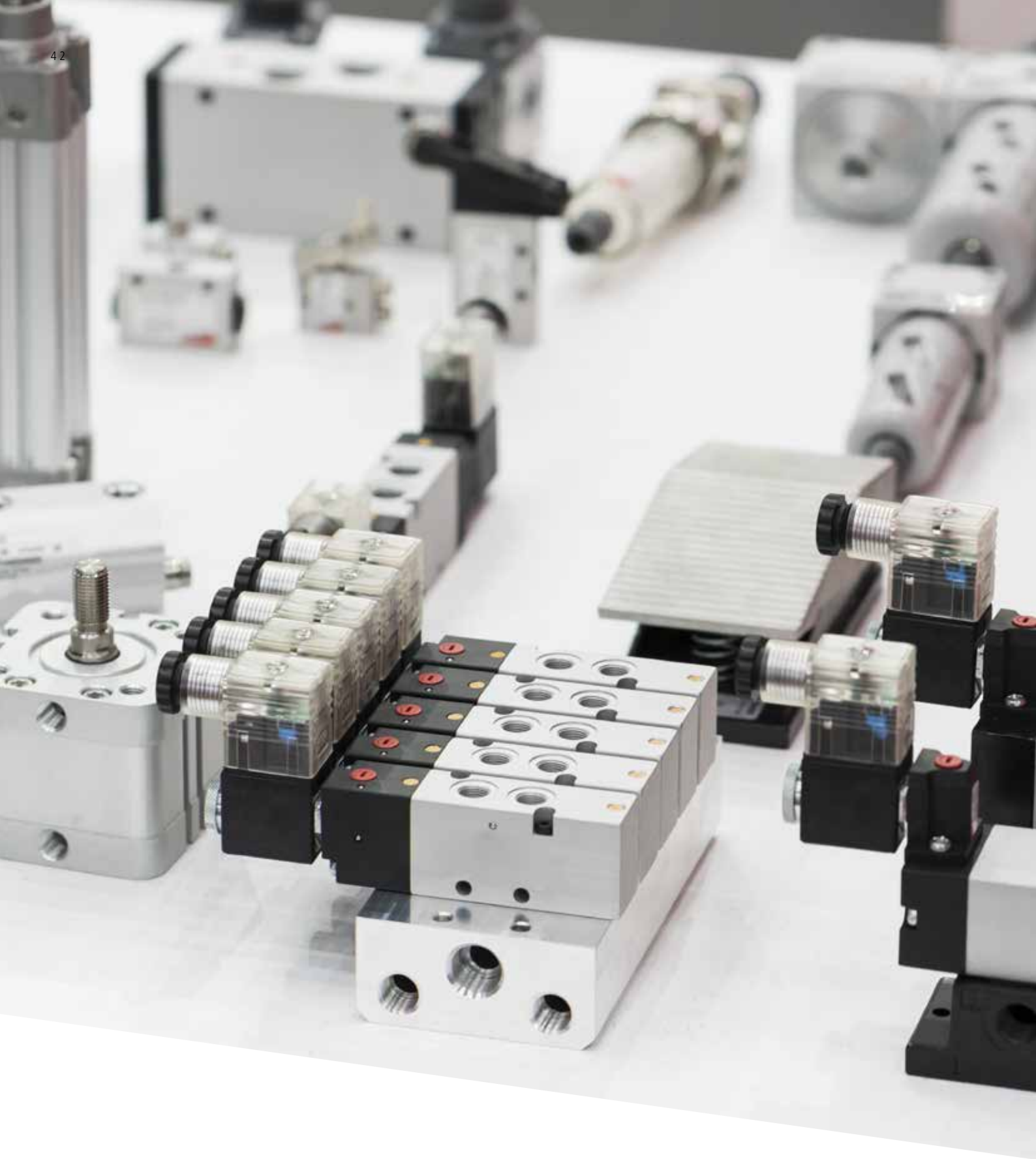

There are also other important industries, such as automobile, aeronautic, medical, electrodomestic, electrical, electronic, writing instruments etc. that trust the production of many components to the reliability of Mikron Machining Technology for accuracy and quality.

HYDRAULIC & PNEUMATIC COMPONENTS



Pump Housing
on Mikron Multistep XT-200



Hydrostatic Steering Unit
on Mikron Multistep XT-200



Hydraulic Valve
on Mikron Multistep XT-200



Mixing Valve
on Mikron Multistep XT-200



Hydraulic Valve Body
on Mikron Multistep XT-200



Hydraulic Cylinder Cover
on Mikron Multistep XT-200



Tandem Valve
on Mikron Multistep XT-200



Pneumatic Valve
on Mikron Multistep XT-200



Solenoid Valve Body
on Mikron Multistep XT-200



Valve Body
on Mikron Multistep XT-200



Valve Body
on Mikron Multistep XT-200



Pneumatic Cylinder Cover
on Mikron Multistep XT-200



110+ YEARS

OF PRECISION EXPERTISE



BICYCLE



To improve quality while reducing the cost per part, industry leaders rely on Mikron Machining high performance production solutions to produce 100s of Million of bicycle parts yearly.

The future of the global bicycle market looks promising opportunities in the road, mountain, touring, hybrids and electric bikes, along with other bicycle related segments. The global bicycle market is expected to grow considerably. The major drivers for this market are raising fuel prices, government programs to build bicycle paths and roads, increasing health concerns/fitness consciousness, growing environmental awareness / trend to carbon neutrality, and increasing traffic congestion.

Emerging trends, which have a direct impact on the dynamics of the industry, include increasing trend of bike sharing, development of folding bicycles, and custom fit bicycles.

Far more eco-friendly than a car and safer than a motorcycle, electric bikes are gaining traction

BICYCLE COMPONENTS





With the Mikron Multistar LX-24 for the production of bicycle nipples best cost per part ratios are achieved while increasing part quality.

CASE HISTORY Bicycle Nipples

On Mikron Multistar LX-24



The challenge

- » Produce bicycle nipples \varnothing 4mm, length 12mm, thread length 8mm
- » Annual production volume approx. 100 mio nipples
- » Material: Brass

The traditional solution

Production area: **25 m²**

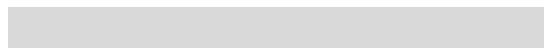

Required machines: **4***



Necessary statistic control: **4**



Necessary tools: **24**



Employees: **1 every 4 machines**



- Raw material: starting from pressed blanks

* Traditional transfer machines

Mikron: The innovative solution

Production area: **16 m²**



Required machines: **1 Mikron Multistar LX-24**



Necessary statistic control: **1 for constant quality**



Necessary tools: **20**



Employees: **0.25/machine**



- Raw material: starting from pressed blanks

Your advantage

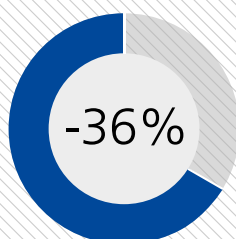

Production area

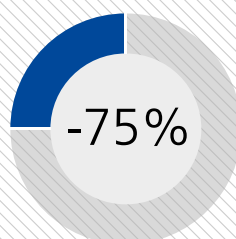

Machines

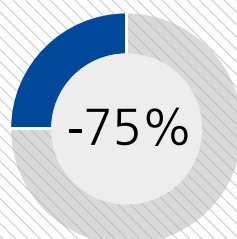

Quality measurements

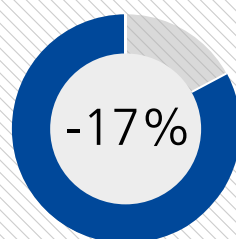

Tools

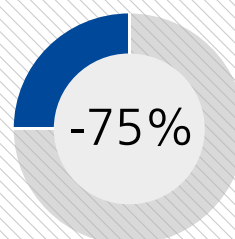

Employees

HOUSEHOLD GOODS



We are surrounded by it everyday. Mastering your daily life using home appliances with components produced on Mikron high performance systems.

Household appliances with parts produced on Mikron high performance systems include:

- » Refrigerators
- » Clima systems
- » Coffee machines
- » Locks
- » Gas appliances
- » Wall socket & connectors
- » Hi-Fi & network Optical connector
- » Fire extinguishing system

HOUSEHOLD GOODS

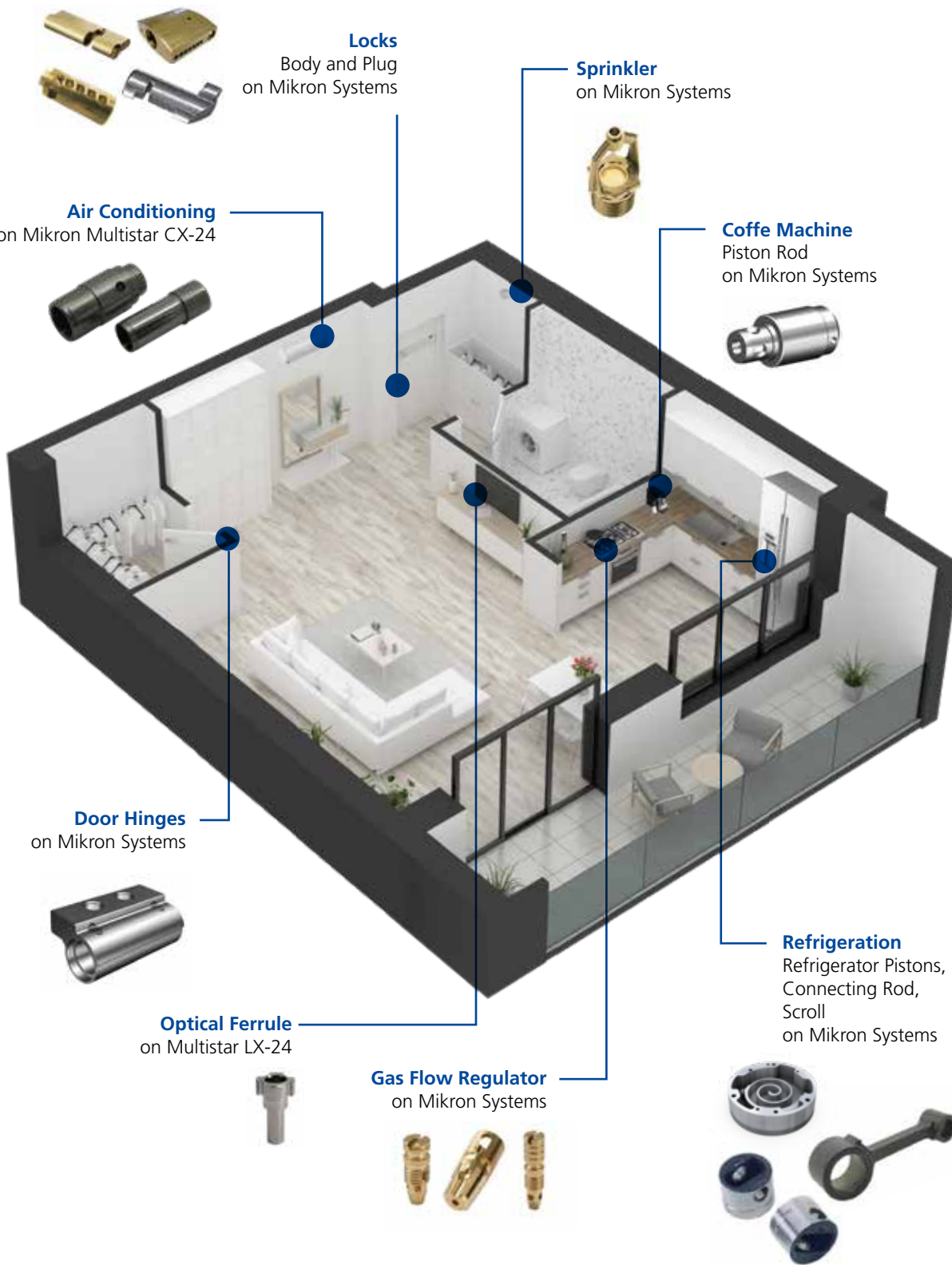



To improve quality while reducing the cost per part industry leaders rely on Mikron Machining high performance production solutions.

CASE HISTORY Air Conditioning

On Mikron Multistar CX-24



The challenge

- » **50+50 million parts per year**
- » 2 pieces made in SUS303 steel, with turning, drilling & deburring operations
- » Tolerances: 2.5µm roundness / $\pm 10\mu\text{m}$ Cmk 1.67 (systematic sampling 10%)



The traditional solution

Production area: **5000 m²**



Required machines: **130**



Efficiency: **80-85%**



Employees: **26+26 employees (2 shifts)**



Operations in different clampings:

- Turning 1th and 2nd phase
- Drilling-milling on mill-turn-machines
- Loading/Unloading manually

Mikron: The innovative solution

Production area: **850 m²**



Required machines: **9 Mikron CX-24 + 10 lathes**



Efficiency: **85-90%**



Employees: **8+8 employees (2 shifts)**



Operations in different clampings:

- Mainly in 1 single clamping
- Loading-unloading mainly automatically

Your advantage

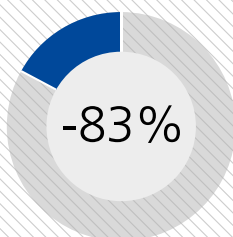

Production area

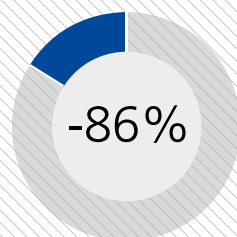

Machines

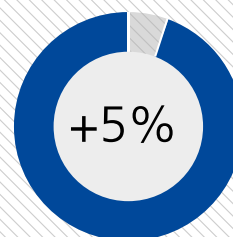

Efficiency

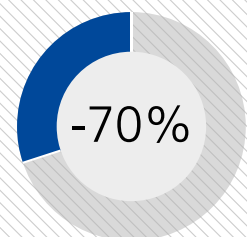

Employees

MEDICAL COMPONENTS

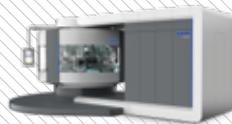

A full range of proven platforms allows Mikron to provide its customers in the pharma and medtech industries with the best solutions for their needs.

Prefect production solutions for:

- » Screw heads for polyaxial and monoaxial screws.
- » Plates to ensure fixation after surgical treatment.
- » Dental implants including dental brackets and screw supports or dental expander for braces.
- » Dialysis pump elements
- » Surgical needles

MEDICAL COMPONENTS

Dialysis Pump Elements
on Mikron NRG



Surgical Needle
on Mikron Multistar LX-24



Orthopedics Implant Tool
on Mikron Multistar CX-24



Bone Screw
on Mikron Systems



Bone Plate
on Mikron Systems



Dental Screw Support
on Mikron VX



Dental Expander
on Mikron VX



Dental Bracket
on Mikron VX

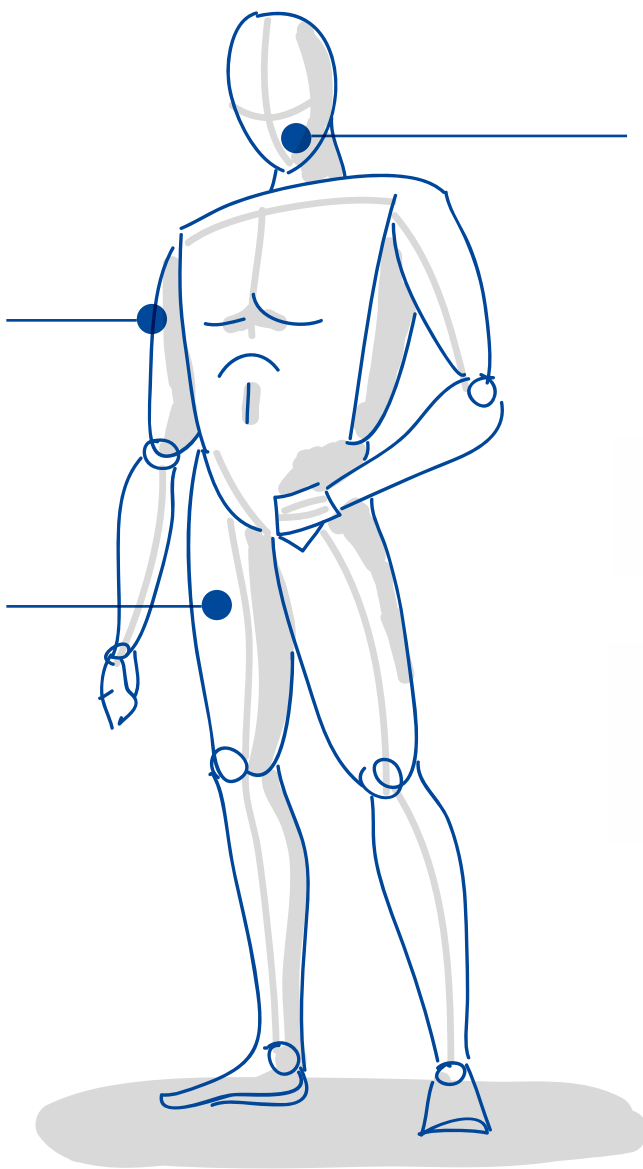

WRITING



Mikron Machining Technology's past is closely linked to the history of the ball point pen. Since the early stages of the ballpoint pen, Mikron has developed machinery to manufacture writing tips.

Tipmanufacturing

As the cost of pens has been reduced over the years, Mikron has developed more and more productive machines. Ballpentips, whether made from brass, nickel-silver or stainless steel are efficiently produced on the Mikron MultistarLX-24 Writing machines. Tips can be made automatically from coldformedblanks or directly from wire stock. Production output ranges from 80 to 300 finished tips per minute.

Wire cutting machine Mikron TR-42 WRI

The Mikron TR-42 is a machine for the economical and straight shearing of wire metal. The machine for cost-effective straight shearing of wire with diameters up to 3 mm for steel, or 5 mm for aluminium and Steel transfer.

Cold heading press Mikron RP-32

As a single stroke cold header, the 6 steeltransfer press RP-32/3 is best suited for small, simple parts. The die centering device ensures precise coaxial alignment of the various diameters. The maximum wire diameter is 3 mm for brass and 4 mm for aluminium.

Working Process

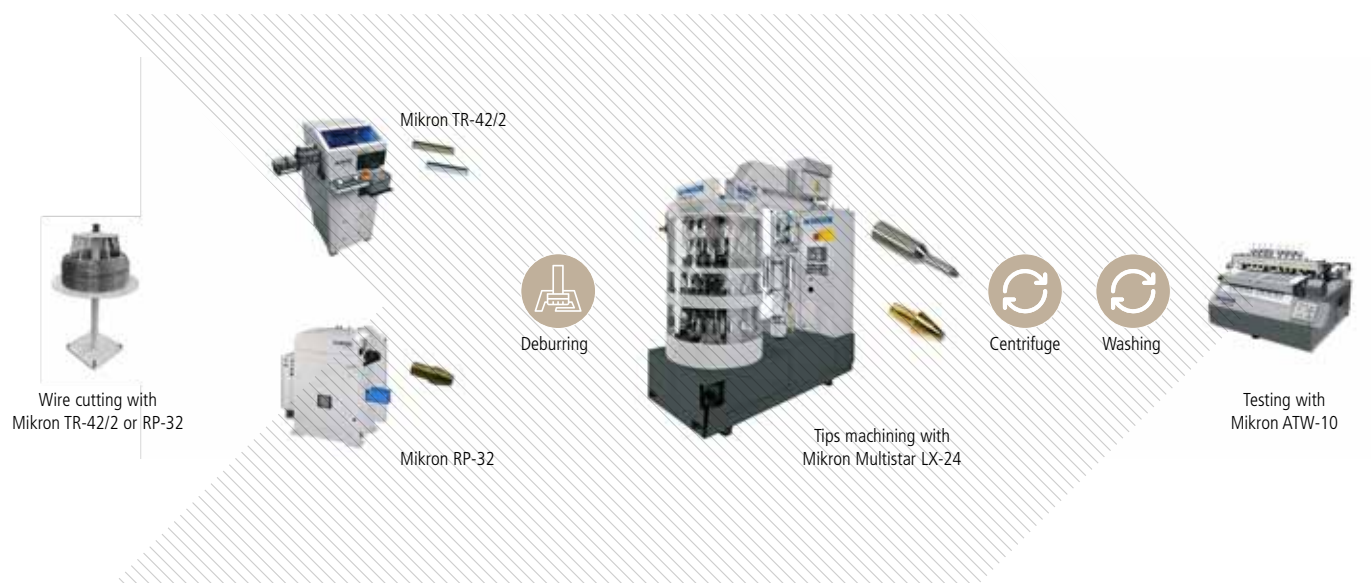



Mikron supplies equipment which meets the specific requirements of the writing instrument manufacturers and is renowned for planning and implementing cost-efficient manufacturing facilities for tips.

WRITING BALL PEN TIPS



Ball pen tip
Stainless steel 160 pcs/min
on Mikron Multistar LX-24



Ball pen tip
Stainless steel 160 pcs/min
on Mikron Multistar LX-24



Ball pen tip
Brass Nickel 200 pcs/min
on Mikron Multistar LX-24



Ball pen tip
Brass 300 pcs/min
on Mikron Multistar LX-24



Ball pen tip
Brass 240 pcs/min
on Mikron Multistar LX-24



Needle tube tip
Stainless steel 150 pcs/min
on Mikron Multistar LX-24

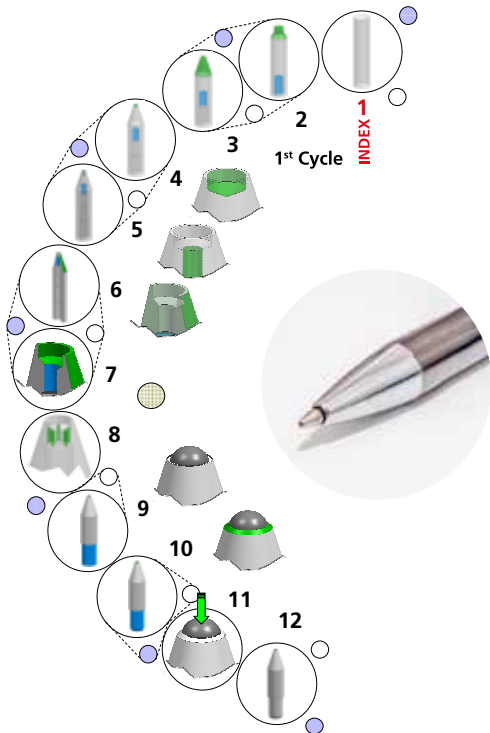

Mikron Multistar machines work to the most demanding tolerances in the industry and are thus ideally suited to produce not only the ordinary ballpen tips but also close tolerance rollerball and gel ink tips. In fact, most of the leading ballpen brands use writing tips made on Mikron equipment.

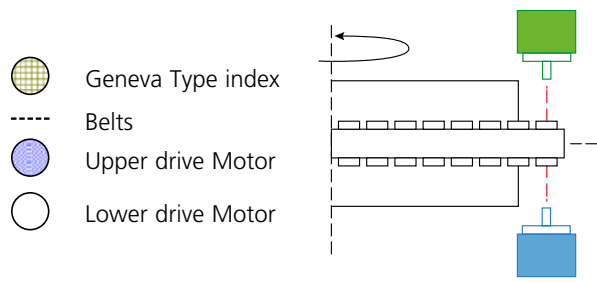
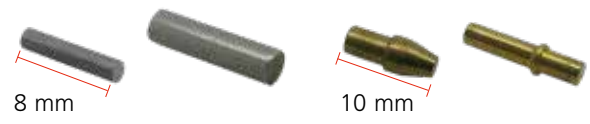



200'000'000

**BALL PEN TIPS PRODUCED DAILY
ON MIKRON SYSTEMS,
95% OF ALL TIPS WORLDWIDE**





Mikron Multistar
LX-24



Mikron Multistar
CX-24

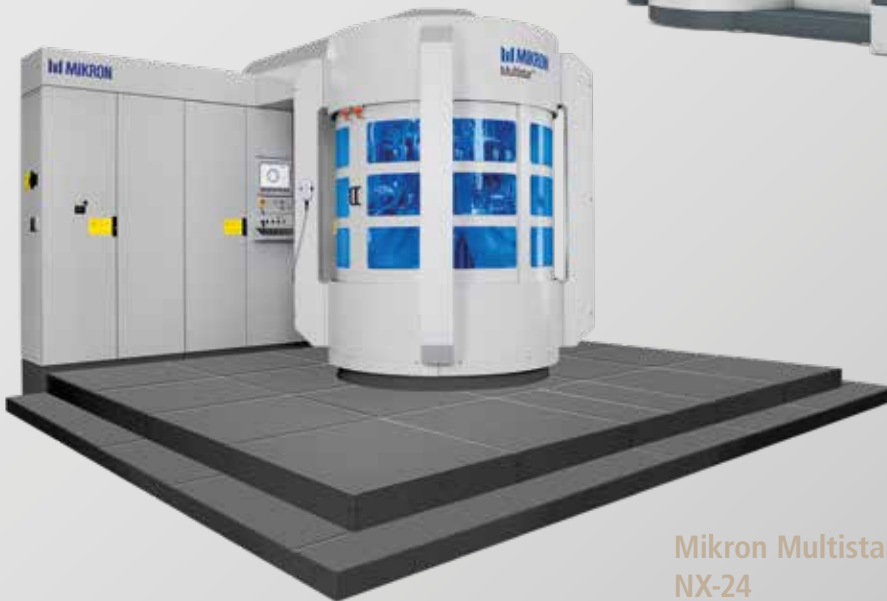

Mikron Multistar
NX-24

The fastest transfer machine
in the world

Mikron Multistar

Models available

- » **Mikron Multistar LX-24**
- » **Mikron Multistar CX-24**
- » **Mikron Multistar NX-24 (100% programmable)**
- » Workpiece size: diameter from 0.4 up to 35 mm and max. length of 60 mm
- » Machine with 12 or 24 stations
- » Compact construction
- » Full CNC or mechanically driven versions
- » Available with one, up to 4 simultaneous cycles, depending on the part complexity and the required volumes
- » In single cycle output up to 150 parts/minute
- » Quick and simple tool change

Mikron Multistar LX-24: That way you can quadruplicate your productivity

The Multistar LX-24 with 24 work stations and up to 44 working spindles ensures a smooth mass production. With the Multistar LX-24, parts can be machined from below and above or from the side. Other additional features are the 24 intermediate stations, which allow measurement, monitoring and cleaning procedures during the same run.

A highly unique system! Up to 600 simple workpieces can be produced per minute. Separating the work fields doubles, triples or quadruples the production rate at the same high processing speed. This same parallel concept enables complete production of different workpieces is possible within a single run.

Mikron Multistar CX-24: A top performer!

What makes the Multistar CX-24 so special? Its unbeatable precise performance and speed. The Multistar CX-24 controls spindle movements with linear curves. The quickly interchangeable control curves provide processing flexibility, and 24 additional intermediate stations enable measuring, turning over of the workpiece – also in different shape, monitoring and cleaning procedures in the processing cycle.

Advantages at a glance:

- » Precise serial production of part families and demanding workpieces
- » $\pm 2.5 \mu\text{m}$ table index accuracy
- » Up to 44 machining units operating simultaneously at 24 stations, assuring a very high output rate

Mikron Multistar NX-24: The best of productivity with full CNC flexibility

The ideal solution for cost-effective batch production of a few hundred to many thousand parts from materials such as alloy steel, brass, titanium or aluminium – with maximum dimensions of $\varnothing 35$ mm and maximum lengths of up to 65 mm. Up to 44 machining units operating simultaneously at 24 stations, assuring a very high output rate.

- » 100% programmable and 100% versatile – all axes electronically controlled for fast changeover
- » Capacity of up to 30 pieces/minute
- » High precision

Mikron VX

Machining on 6-sides, from bar, wire or blank

- » Full CNC high precision rotary transfer machine with 10 or 12 workstations for the production of variable batch sizes.
- » Maximum workpiece dimensions up to 40x40x80 mm (optional 40x40x160)
- » Vertical table, thermostable main motor with inner cooling for maximum precision
- » Table positioning: $\pm 2 \mu\text{m}$
- » Complete machining on 6 faces from coil, bar or blank
- » 4-axis pre-machining of bar before clamping



Mikron VX-10

Mikron NRG

The new generation of transfer machines

- » Full CNC high-precision rotary transfer machine
- » Workpiece dimension: up to 80 x 80 x 80 mm and $\varnothing 65 \times 100$ mm
- » Compact and modular construction with 12 stations, anytime adaptable to individual production needs
- » ATS (Advanced Thermal Stabilization): the temperature of all elements remains stable
- » Up to 3 machining units per station
- » Up to 30 machining units work simultaneously
- » Up to 22 automatic tool changers (ATC) on board
- » Up to 96 cutting tools on board
- » Machining on 6 faces in one clamping
- » Milling or drilling on one station with three units simultaneously
- » Per spindle interpolation with up to 5 CNC-axis



Mikron NRG

Mikron Multistep XT-200

Advantage through modularity

- » 5 1/2 side machining, simultaneously with 5 axis in a single clamping
- » The loading module can perform parallel tasks such as, for example, fully automated repositioning of work-pieces for 6th-side machining, dimensional checking of blanks, deburring, cleaning and much more...
- » Chip-to-chip in less than one second
- » 2x tool magazine discs with 18 tool slots, up to 36 tools per module. When stacked to the maximum level (4 modules), the Multistep XT-200 can accommodate 144 tools
- » 2x alternately operating spindles, chip-to-chip time under 1 second at full spindle speed
- » 1x B/C- axis: The extremely stable table guarantees stable machining even with heavy load operations
- » Options: electronic tool wear detector – tool breakage detection with mechanical sensor – tool coding with chip and reader
- » Twin gripper transfer arm for transporting work-pieces (clamped in the fixture) between the machining modules
- » Slanted machine bed for optimal chip removal



Mikron Multistep XT-200

Mikron MultiX

Unrivalled possibilities - Dedicated configurable highly productive and flexible machining solutions

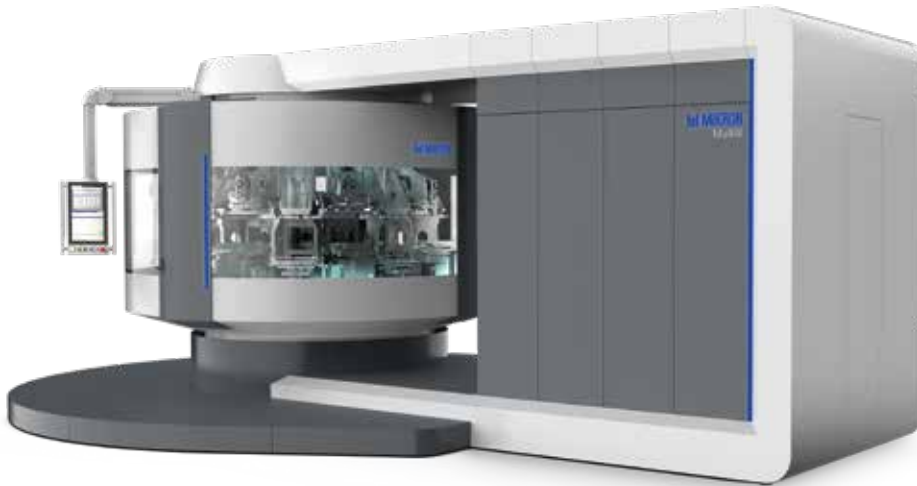

Winner EMO
Innovations award 2019



THE PLATFORM

- » **Freely combine** the platform elements according to the Mikron MultiX rules and set up your machining solution. By choosing the optimal size and architecture for every unit and station you achieve superior productivity by less investment costs.
- » **Distinct technical features:** Direct machining from the bar (turning or milling), 3 machining units working simultaneously at each station, multispindle-lathe and transfer machine capabilities in one single machining system.
- » **A set of diverse machining units in different sizes** to serve all the requirements you might need. The machining units differ in size, number of axis, size of compatible spindles, strokes, stiffness, etc..
- » **Scalable:** Start producing with a single cycle Mikron MultiX configuration and add supplementary cycles according to volume grow

MIKRON MULTIX-P

Available in 10-12-16 Stations

PRODUCTIVITY

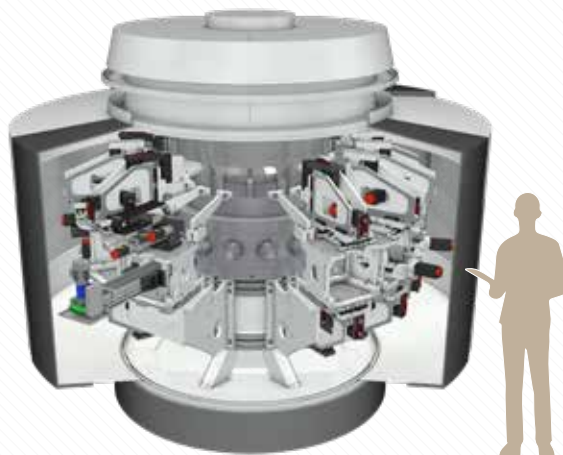

Ø 4.00m

Working area from XxYxZ 50x80x150 up to 210x150x155 mm



GDI pump housing
in 4 different variants
Automotive industry

CONFIGURATION FOR HIGH VOLUME PRODUCTION OF FIST SIZE PARTS. INDEXING THROUGH VERY STIFF AND REPEATABLE HIRTH COUPLING.

- » 16 stations
- » 3-axis machining units
- » Spindle with HSK-63 / -40 / -32
- » Automatic tool changer

FLEXIBILITY: LOT-SIZE ONE

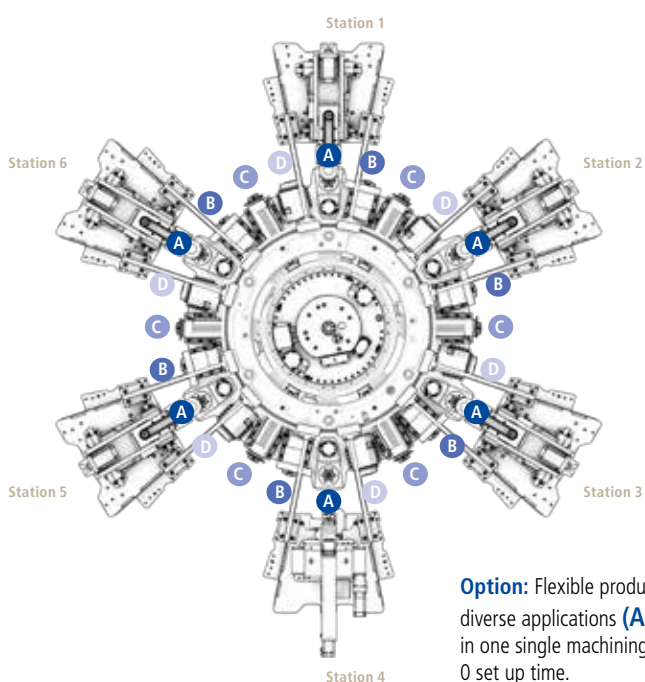
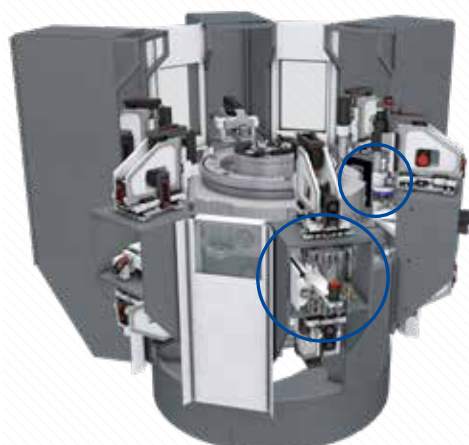

Option: Flexible production of diverse applications (A, B, C, D) in one single machining system, 0 set up time.

UP TO 168 CUTTING-TOOLS AND 4 DIFFERENT CLAMPING SYSTEMS ON BOARD (HORIZONTAL AND/OR VERTICAL)

Automatic Tool Changer available in different versions:

- Spindle with 4 Tools
- Disk with 12 Tools
- Upper and lower disk with each 12 Tools
- Standard HSK-40, HSK-63 on request

MIKRON MULTIX-C

Available in 6-8 Stations

FLEXIBILITY



Ø 4.00m

Working area XxYxZ up to 210x150x155 mm



Part
Job shop

CONFIGURATION FOR HIGHEST FLEXIBILITY AND MASS PRODUCTION.

- » 8 Stations
- » 4 x horizontal clamping, turning
- » 4 x milling 5 axis
- » Spindle with HSK-63 / -40 / -32
- » Automatic tool changer

Mikron miTool

the next level of tool monitoring

Mikron miTool monitoring becomes crucial to avoid unexpected machine downtime, machine breakage, tool damage, material scrap and the likely issues. Surface finish and tolerances can be improved with the detection of tool wear and damaged and expensive tools can be changed before any severe damage takes place.

Mikron miTool is easy to install and customers benefit greatly in terms of efficiency and expenditure.

- » Prevention of damage due to tool breakage or tool overload
- » Sensorless with automated learning of load limits (Option to integrate vibration and temperature sensors)
- » For turning, milling and drilling and smallest tool sizes (up to 1.5 mm diameter)
- » Powerful algorithm for efficient monitoring after the first workpiece. It has a built-in learning function, allowing it to compensate for differences in processes.
- » The system maximizes the service lives of both the tools and Mikron high performance machines



Attractive pricing and fast return on invest

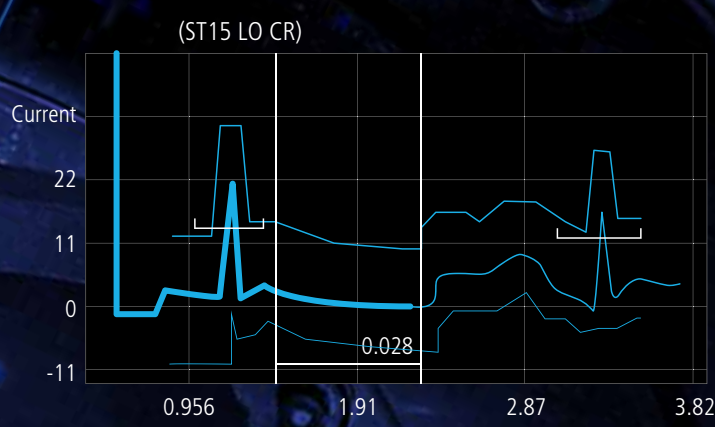

WHAT MAKES Mikron miTool SO SPECIAL FOR YOU

- » Highest sensibility and quality of data points deliver the finest and exact monitoring curves
- » Intuitive icon driven graphical interface for easiest use and monitoring by operators
- » Intelligent algorithm for advanced process optimization and cutting tool wear identification
- » Mikron miTool is able to storage data and history for each tool configuration and monitoring curve
- » Dashboard with statistical overview for each tool allows the optimization of the entire production process
- » Mikron miTool permits all modifications (set up, regulations...) without machine stop
- » Automatic actions programmable for each channel e.g. save data in database, send notification, preventively stop the machine
- » Perfectly integrated into Mikron high performance systems

Intelligent powerful algorithm for optimal intervals to change several cutting tools at the same time leads to higher machine efficiency and economy (less machine stops).

5 CUTTING TOOLS CHANGED AT 5 STOPS

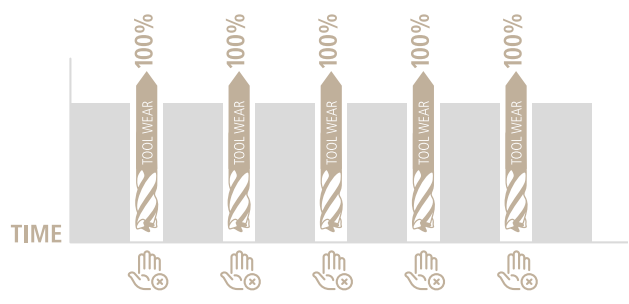

5 CUTTING TOOLS CHANGED AT 1 STOP

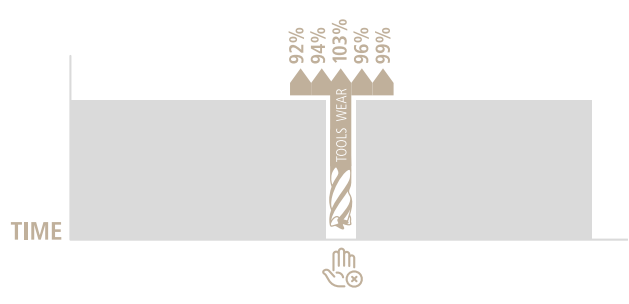

Number of machine stops for cutting tool changes

Case History

Mikron miTool

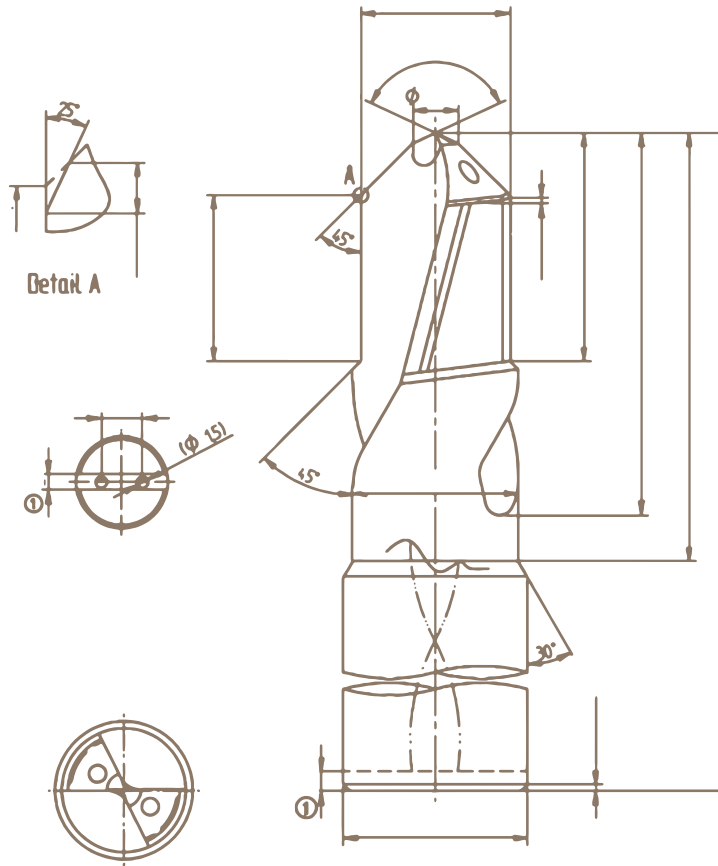

on Mikron VX

The challenge

The customer produces 6.13 mio parts per year (OEE 80%) for the automobile industry on Mikron VX.

Target: Reduce tooling costs, improve part quality and increase machine efficiency.

Productivity	17.4 Pc/min
Daily working time	1'440 min/day
Annual working days	306 days/year
OEE 80%	
6'133'709	Pc/year
Cutting tool costs Station 5	211.00 chf/Cutting tool



CUTTING TOOL MONITORED WITH Mikron miTool STATION 5 (SEE DRAWING ON LEFT):

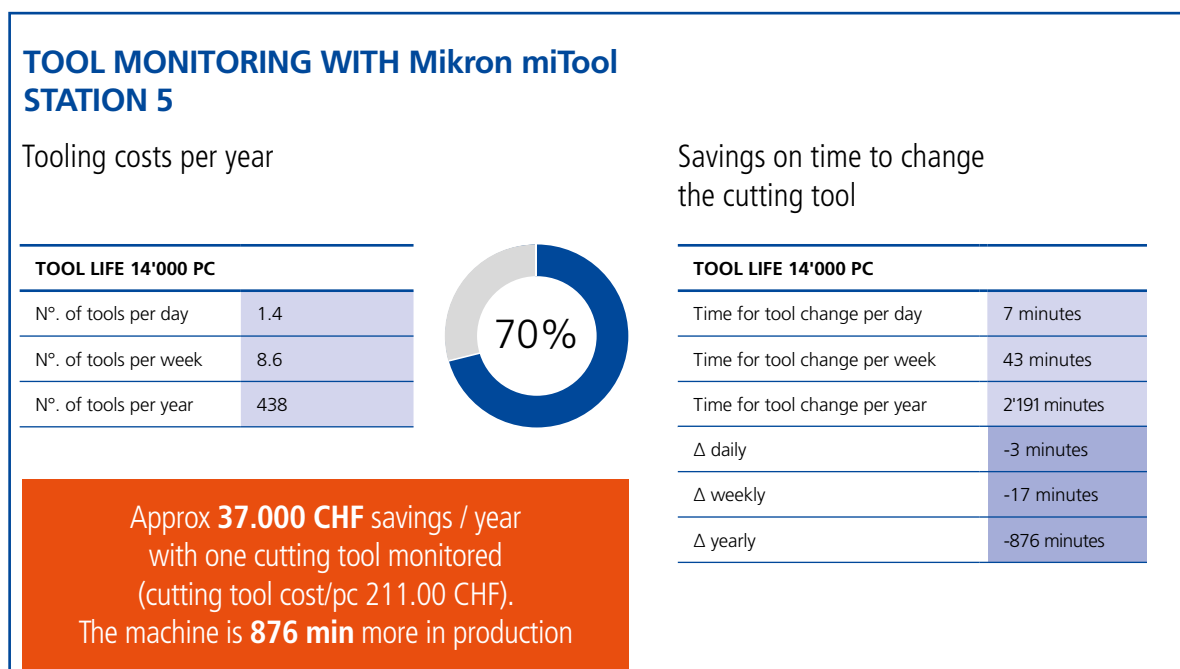
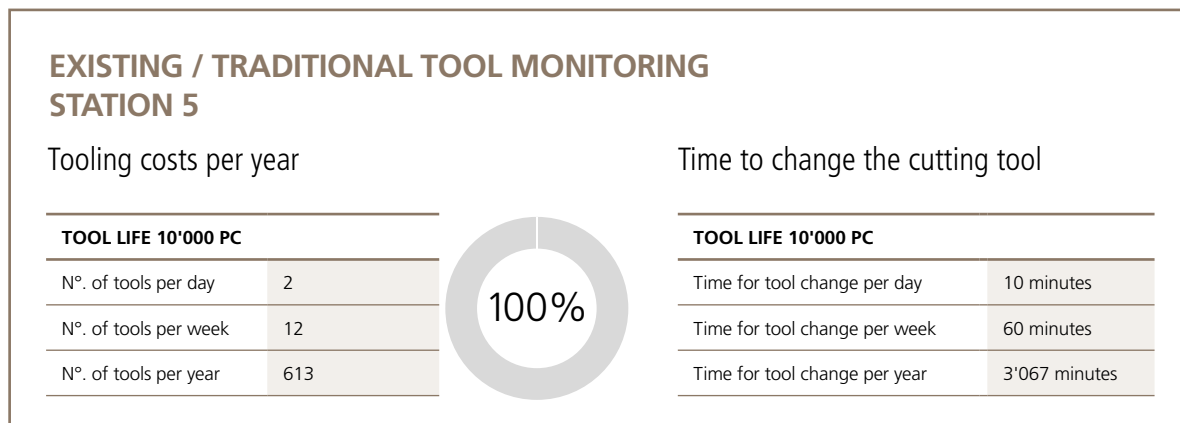

Mikron Machining

Headquarter

Mikron Switzerland AG, Agno
Division Machining

Headquarter

Via Ginnasio 17

6982 Agno

Switzerland

Tel. +41 91 610 61 11

Fax +41 91 610 66 80

mag@mikron.com

Mikron Germany GmbH

Berner Feld 71

D-78628 Rottweil

Tel. +49 741 5380 0

Fax +49 741 5380 580

mro@mikron.com

Mikron Corp. Monroe

200 Main Street

P.O. Box 268

Monroe, CT 06468 / USA

Tel. +1 203 261 31 00

Fax +1 203 268 47 52

mmo@mikron.com



www.youtube.com/mikrongroup
www.mikron.com

Mikron® is a trademark of Mikron Holding AG, Biel (Switzerland).
Pictures and colours of the products here included are samples.
The technical data listed are not binding and may be changed at any time without notice.